

! WARNING

PLEASE READ THE ENTIRE CONTENTS OF THIS MANUAL PRIOR TO INSTALLATION AND OPERATION. BY PROCEEDING YOU AGREE THAT YOU FULLY UNDERSTAND AND COMPREHEND THE FULL CONTENTS OF THIS MANUAL. FORWARD THIS MANUAL TO ALL OPERATORS. FAILURE TO OPERATE THIS EQUIPMENT AS DIRECTED MAY CAUSE INJURY OR DEATH.

REV G 02-07-11

pn# 5900042

CAUTION
The safe operating temperature range for this product is 41° F. - 104 °F.

INSTALLATION AND OPERATION MANUAL

**9,000 POUND CAPACITY
12,000 POUND CAPACITY
SURFACE MOUNTED
TWO POST -
DIRECT DRIVE LIFTS**

**MODELS:
XPR-9FD
XPR-9FDX
XPR-12FD**

VERSION A

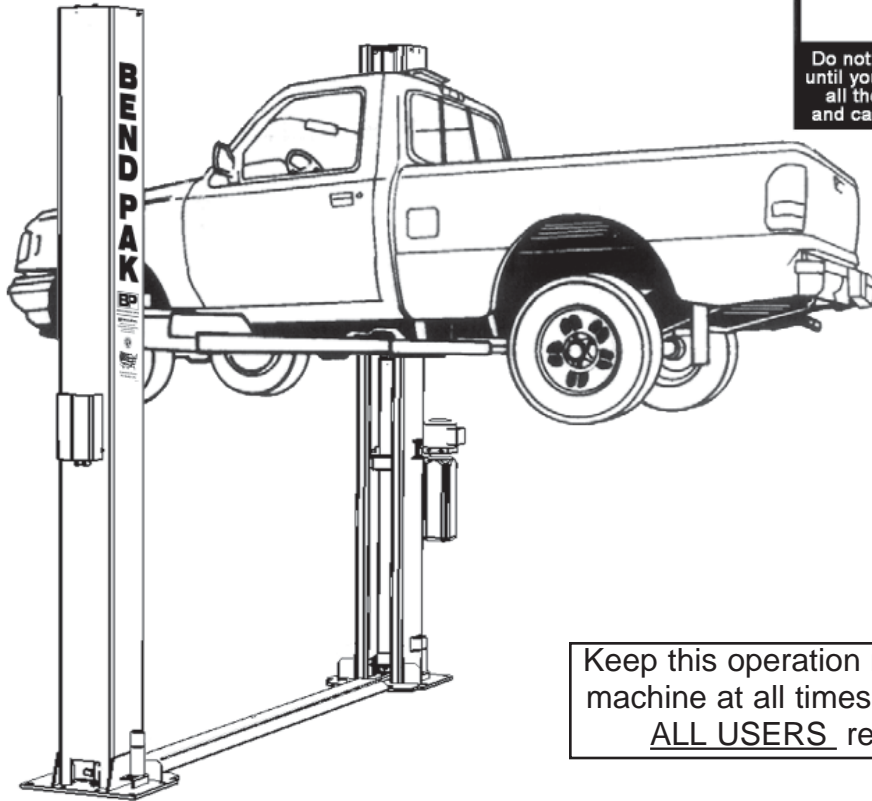

READ FIRST



Do not operate this machine until you read and understand all the dangers, warnings and cautions in this manual.

Keep this operation manual near the machine at all times. Make sure that ALL USERS read this manual .

SHIPPING DAMAGE CLAIMS

When this equipment is shipped, title passes to the purchaser upon receipt from the carrier. Consequently, claims for the material damaged in shipment must be made by the purchaser against the transportation company at the time shipment is received.

BE SAFE

Your new lift was designed and built with safety in mind. However, your overall safety can be increased by proper training and thoughtful operation on the part of the operator. DO NOT operate or repair this equipment without reading this manual and the important safety instructions shown inside.



1645 Lemonwood Dr.
Santa Paula, CA. 93060, USA
Toll Free 1-800-253-2363
Tel: 1-805-933-9970
Fax: 1-805-933-9160
www.bendpak.com

TWO-POST SURFACE MOUNTED AUTO AND LIGHT DUTY TRUCK LIFT

This instruction manual has been prepared especially for you.
Your new lift is the product of over 35 years of continuous research, testing and development;
it is the most technically advanced lift on the market today.

READ THIS ENTIRE MANUAL BEFORE INSTALLATION & OPERATION BEGINS.

RECORD HERE THE LIFT AND
POWER UNIT INFORMATION WHICH IS
LOCATED ON THE SERIAL NUMBER
DATA PLATES ON THE LIFT AND
ON THE POWER UNIT

Power Unit Model # _____
Power Unit Date Of Mfg. _____
Power Unit Serial # _____

This information is required when
calling for parts or warranty issues.

1645 Lemonwood Dr., Santa Paula, CA 93060 USA Tel: 1-805-933-9970 Fax: 1-805-933-9160 www.bendpak.com		
Model No.	Lifting Capacity	Serial No.
Date of Mfg.	Power Unit No.	Voltage / Amperage
Cable Length	A	B
Cable Diameter		

PRODUCT WARRANTY

BendPak 2-Post Lifts are covered under warranty for five years on equipment structure, to be free of defects in material and workmanship. Power units, hydraulic cylinders, and all other assembly components such as turnplates, slip plates, cables, chains, valves, switches etc. are covered under warranty for one year against defects in material or workmanship under normal use. BendPak Inc. shall repair or replace at their option for the warranty period those parts returned to the factory freight prepaid which prove upon inspection to be defective. BendPak Inc. will pay labor costs for the first 12 months only on parts returned as previously described.

The warranty does not extend to...

- ◆ defects caused by ordinary wear, abuse, misuse, shipping damage, improper installation, voltage or lack of required maintenance;
- ◆ damages resulting from purchaser's neglect or failure to operate products in accordance with instructions provided in the owner's manual(s) and/or other accompanying instructions supplied;
- ◆ normal wear items or service normally required to maintain the product in a safe operating condition;
- ◆ any component damaged in shipment;
- ◆ other items not listed but may be considered general wear parts;
- ◆ damage caused by rain, excessive humidity, corrosive environments or other contaminants.

THESE WARRANTIES DO NOT EXTEND TO ANY COSMETIC DEFECT NOT INTERFERING WITH EQUIPMENT FUNCTIONALITY OR ANY INCIDENTAL, INDIRECT, OR CONSEQUENTIAL LOSS, DAMAGE, OR EXPENSE THAT MAY RESULT FROM ANY DEFECT, FAILURE, OR MALFUNCTION OF A BENDPAK INC. PRODUCT OR THE BREACH OR DELAY IN PERFORMANCE OF THE WARRANTY.

**WARRANTY IS NOT VALID UNLESS
WARRANTY CARD IS RETURNED.**

IMPORTANT NOTICE

Do not attempt to install this lift if you have never been trained on basic automotive lift installation procedures. Never attempt to lift components without proper lifting tools such as forklift or cranes. Stay clear of any moving parts that can fall and cause injury. These instructions must be followed to insure proper installation and operation of your lift. Failure to comply with these instructions can result in serious bodily harm and void product warranty. Manufacturer will assume no liability for loss or damage of any kind, expressed or implied resulting from improper installation or use of this product.

PLEASE READ ENTIRE MANUAL PRIOR TO INSTALLATION.

DEFINITIONS OF HAZARD LEVELS

Identify the hazard levels used in this manual with the following definitions and signal words:



DANGER !

Watch for this symbol: It Means: Immediate hazards which will result in severe personal injury or death.



WARNING !

Watch for this symbol: It Means: Hazards or unsafe practices which could result in severe personal injury or death.



CAUTION !

Watch for this symbol: It Means: Hazards or unsafe practices which may result in minor personal injury, product or property damage.

OWNER'S RESPONSIBILITY

To maintain the lift and user safety, the responsibility of the owner is to read and follow these instructions:

- ◆ Follow all installation and operation instructions.
- ◆ Make sure installation conforms to all applicable Local, State, and Federal Codes, Rules, and Regulations; such as State and Federal OSHA Regulations and Electrical Codes.
- ◆ Carefully check the lift for correct initial function.
- ◆ Read and follow the safety instructions. Keep them readily available for machine operators.
- ◆ Make certain all operators are properly trained, know how to safely and correctly operate the unit, and are properly supervised.
- ◆ Allow unit operation only with all parts in place and operating safely.
- ◆ Carefully inspect the unit on a regular basis and perform all maintenance as required.
- ◆ Service and maintain the unit only with authorized or approved replacement parts.
- ◆ Keep all instructions permanently with the unit and all decals on the unit clean and visible.

BEFORE YOU BEGIN

Receiving:

The shipment should be thoroughly inspected as soon as it is received. The signed bill of lading is acknowledgement by the carrier of receipt in good condition of shipment covered by your invoice. If any of the goods called for on this bill of lading are shorted or damaged, do not accept them until the carrier makes a notation on the freight bill of the shorted or damaged goods. Do this for your own protection.

NOTIFY THE CARRIER AT ONCE if any hidden loss or damage is discovered after receipt and request the carrier to make an inspection. If the carrier will not do so, prepare a signed statement to the effect that you have notified the carrier (on a specific date) and that the carrier has failed to comply with your request.

IT IS DIFFICULT TO COLLECT FOR LOSS OR DAMAGE AFTER YOU HAVE GIVEN THE CARRIER A CLEAR RECEIPT. File your claim with the carrier promptly. Support your claim with copies of the bill of lading, freight bill, invoice, and photographs, if available. Our willingness to assist in helping you process your claim does not make BendPak responsible for collection of claims or replacement of lost or damaged materials.

TABLE OF CONTENTS

<u>Contents</u>	<u>Page No.</u>
Warranty / Serial Number Information2
Definitions of Hazard Levels	3
Owner's Responsibility	3
Before You Begin.	3
Installer Agreement / Protective Equipment.	5
Introduction.	6
Safety / Warning Instructions	6
Tools Required.	7
Step 1 / Selecting Site	7
Step 2 / Floor Requirements	7
Concrete Specifications.	7
Assembly View / Description of Parts.	8
Floor Plan / Specifications	9
Power Unit Location.	9
Step 3 / Preparing Columns.	9
Step 4 / Site Layout	10
Step 5 / Installing Powerside Columns.	10-11
Step 6 / Installing Offside Columns	10-11
Step 7 / Mounting Power Unit	12
Step 8 / Installation of Safeties and Safety Cables.	13-14
Step 9 / Installation of Hydraulic Lines.	15
Step 10 / Routing Equalizer Cables	16-17
Step 11 / Installing Safety Covers.	17
Installing the Lift Arms	18-19
Leveling Instructions	20
Carriage Stop Bolt Warning	21
Step 12 / Power Unit Hookup	22-24
Step 13 / Lift Startup/ Final Adjustments	24
Post Installation Check List	25
Step 14 / Lubrication	25
Step 15 / Bleeding	25
Optional Equipment Installation	26-27
Step 16 / Operation/ Maintenance	28-39
Troubleshooting Guide	40-43
Parts Lists	44-50
Installation Form	51

**INSTALLER / OPERATOR
PLEASE READ AND FULLY
UNDERSTAND.
BY PROCEEDING YOU AGREE TO
THE FOLLOWING.**

- ◆ I have visually inspected the site where the lift is to be installed and verified the concrete to be in good condition and free of cracks or other defects. I understand that installing a lift on cracked or defective concrete could cause lift failure resulting in personal injury or death.
- ◆ I understand that a level floor is required for proper installation and level lifting.
- ◆ I understand that I am responsible if my floor is of questionable slope and that I will be responsible for all charges related to pouring a new level concrete slab if required and any charges.
- ◆ I understand that Bendpak lifts are supplied with concrete fasteners meeting the criteria of the American National Standard "Automotive Lifts - Safety Requirements for Construction, Testing, and Validation" ANSI/ALI ALCTV-2006, and that I will be responsible for all charges related to any special regional structural and/or seismic anchoring requirements specified by any other agencies and/or codes such as the Uniform Building Code (UBC) and/or International Building Code (IBC).
- ◆ I will assume full responsibility for the concrete floor and condition thereof, now or later, where the above equipment model(s) are to be installed. Failure to follow danger, warning, and caution instructions may lead to serious personal injury or death to operator or bystander or damage to property.
- ◆ I understand that Bendpak lifts are designed to be installed in indoor locations only. Failure to follow installation instructions may lead to serious personal injury or death to operator or bystander or damage to property or lift.



Failure to follow danger, warning, and caution instructions may lead to serious personal injury or death to operator or bystander or damage to property.



Please read entire manual prior to installation. Do not operate this machine until you read and understand all the dangers, warnings and cautions in this manual. For additional copies or further information, contact:

BendPak Inc. / Ranger Products

1645 Lemonwood Dr.

Santa Paula, CA. 93060

1-805-933-9970

www.bendpak.com

**INSTALLER / OPERATOR
PROTECTIVE EQUIPMENT**

Personal protective equipment helps makes installation and operation safer, however, it does not take the place of safe operating practices. Always wear durable work clothing during any installation and/or service activity. Shop aprons or shop coats may also be worn, however loose fitting clothing should be avoided. Tight fitting leather gloves are recommended to protect technician hands when handling parts. Sturdy leather work shoes with steel toes and oil resistant soles should be used by all service personnel to help prevent injury during typical installation and operation activities.

Eye protection is essential during installation and operation activities. Safety glasses with side shields, goggles, or face shields are acceptable. Back belts provide support during lifting activities and are also helpful in providing worker protection. Consideration should also be given to the use of hearing protection if service activity is performed in an enclosed area, or if noise levels are high.



THIS SYMBOL POINTS OUT IMPORTANT SAFETY INSTRUCTIONS WHICH IF NOT FOLLOWED COULD ENDANGER THE PERSONAL SAFETY AND/OR PROPERTY OR YOURSELF AND OTHERS AND CAN CAUSE PERSONAL INJURY OR DEATH. READ AND FOLLOW ALL INSTRUCTIONS IN THIS MANUAL BEFORE ATTEMPTING TO OPERATE THIS MACHINE.

INTRODUCTION

1. Carefully remove the crating and packing materials. **CAUTION!** Be careful when cutting steel banding material as items may become loose and fall causing personal harm or injury.

2. Check the voltage, phase and proper amperage requirements for the motor shown on the motor plate. Wiring should be performed by a certified electrician only.

IMPORTANT SAFETY INSTRUCTIONS !

Read these safety instructions entirely!

IMPORTANT NOTICE!

Do not attempt to install this lift if you have never been trained on basic automotive lift installation procedures.

Never attempt to lift components without proper lifting tools such as forklift or cranes.

Stay clear of any moving parts that can fall and cause injury.

1. **READ AND UNDERSTAND** all safety warning procedures before operating lift.

2. **KEEP HANDS AND FEET CLEAR.** Remove hands and feet from any moving parts. Keep feet clear of lift when lowering. Avoid pinch points.

3. **KEEP WORK AREA CLEAN.** Cluttered work areas invite injuries.

4. Consider work area environment. Do not expose equipment to rain. **DO NOT** use in damp or wet locations. Keep area well lighted.

5. **ONLY TRAINED OPERATORS** should operate this lift. All non-trained personnel should be kept away from work area. Never let non-trained personnel come in contact with, or operate lift.

6. **USE LIFT CORRECTLY.** Use lift in the proper manner. Never use lifting adapters other than what is approved by the manufacturer.

7. **DO NOT** override self-closing lift controls.

8. **REMAIN CLEAR** of lift when raising or lowering vehicle.

9. **CLEAR AREA** if vehicle is in danger of falling.

10. **ALWAYS INSURE** that the safeties are engaged before any attempt is made to work on or near vehicle.

11. **DRESS PROPERLY.** Non-skid steel-toe footwear is recommended when operating lift.

12. **GUARD AGAINST ELECTRIC SHOCK.** This lift must be grounded while in use to protect the operator from electric shock. Never connect the green power cord wire to a live terminal. This is for ground only.



13. **DANGER!** The power unit used on this lift contains high voltage. Disconnect power at the receptacle before performing any electrical repairs. Secure plug so that it cannot be accidentally plugged in during service.



14. **WARNING! RISK OF EXPLOSION.** This equipment has internal arcing or sparking parts which should not be exposed to flammable vapors. This machine should not be located in a recessed area or below floor level.



15. **MAINTAIN WITH CARE.** Keep lift clean for better and safer performance. Follow manual for proper lubrication and maintenance instructions. Keep control handles and/or buttons dry, clean and free from grease and oil.

16. **STAY ALERT.** Watch what you are doing. Use common sense. Be aware.

17. **CHECK FOR DAMAGED PARTS.** Check for alignment of moving parts, breakage of parts or any condition that may affect its operation. Do not use lift if any component is broken or damaged.

18. **NEVER** remove safety related components from the lift. Do not use lift if safety related components are damaged or missing.

TOOLS REQUIRED

- ◆ Rotary Hammer Drill or Similar
- ◆ 3/4" Masonry Bit
- ◆ Hammer
- ◆ 4 Foot Level
- ◆ Open-End Wrench Set: SAE/Metric
- ◆ Socket And Ratchet Set: SAE/Metric
- ◆ Hex-Key / Allen Wrench Set
- ◆ Large Crescent Wrench
- ◆ Large Pipe Wrench
- ◆ Crow Bar
- ◆ Chalk Line
- ◆ Medium Flat Screwdriver
- ◆ Tape Measure: 25 Foot Minimum
- ◆ Needle Nose Pliers

IMPORTANT NOTICE !

These instructions must be followed to insure proper installation and operation of your lift. Failure to comply with these instructions can result in serious bodily harm and void product warranty. Manufacturer will assume no liability for loss or damage of any kind, expressed or implied resulting from improper installation or use of this product.

PLEASE READ ENTIRE MANUAL PRIOR TO INSTALLATION !

STEP 1

(Selecting Site)

Before installing your new lift, check the following.

1. **LIFT LOCATION:** Always use architects plans when available. Check layout dimension against floor plan requirements making sure that adequate space is available.
2. **OVERHEAD OBSTRUCTIONS:** The area where the lift will be located should be free of overhead obstructions such as heaters, building supports, electrical lines etc.
3. **DEFECTIVE FLOOR:** Visually inspect the site where the lift is to be installed and check for cracked or defective concrete.



4. **OPERATING TEMPERATURE.** Operate lift only between temperatures of 41° -104° F.
5. Lift is designed for **INDOOR INSTALLATION ONLY.**

STEP 2

(Floor Requirements)



This lift must be installed on a solid level concrete floor with no more than 3-degrees of slope. Failure to do so could cause personal injury or death.

A level floor is suggested for proper use and installation and level lifting. If a floor is of questionable slope, consider a survey of the site and/or the possibility of pouring a new level concrete slab.



- ◆ **DO NOT** install or use this lift on any asphalt surface or any surface other than concrete.
- ◆ **DO NOT** install or use this lift on expansion seams or on cracked or defective concrete.
- ◆ **DO NOT** install or use this lift on a second / elevated floor without first consulting building architect.
- ◆ **DO NOT** install or use this lift outdoors.

CONCRETE SPECIFICATIONS

LIFT MODEL	CONCRETE REQUIREMENTS
9,000 Lb. Models	4" Min. Thickness / 3000 PSI
12,000 Lb. Model	6" Min. Thickness / 3000 PSI



DANGER!

All models **MUST** be installed on 3000 PSI concrete only conforming to the minimum requirements shown above. New concrete must be adequately cured by at least 28 days minimum.

IMPORTANT NOTE:

BendPak lifts are supplied with installation instructions and concrete fasteners meeting the criteria as prescribed by the American National Standard "Automotive Lifts - Safety Requirements for Construction, Testing, and Validation" ANSI/ALI ALCTV-2006. Lift buyers are responsible for any special regional structural and/or seismic anchoring requirements specified by any other agencies and/or codes such as the Uniform Building Code (UBC) and/or International Building Code (IBC).

! DANGER

When removing the lift from shipping angles pay close attention as the posts can slide and can cause injury. Prior to removing the bolts make sure the posts are held securely by a fork lift or some other heavy lifting devise.

PARTS INVENTORY
Be sure to take a complete inventory of parts prior to beginning installation.

Description	Qty
Floor Plate	1
Front Arm Assembly	2
Rear Arm Assembly	2
Offside Column with Lift Head Assembly	1
Powerside Column with Lift Head Assembly	1
Hydraulic Cylinder	2
Parts Box (Packing List Enclosed)	1
Parts Bag (Packed in Part Box)	1
Hydraulic Power Unit	1

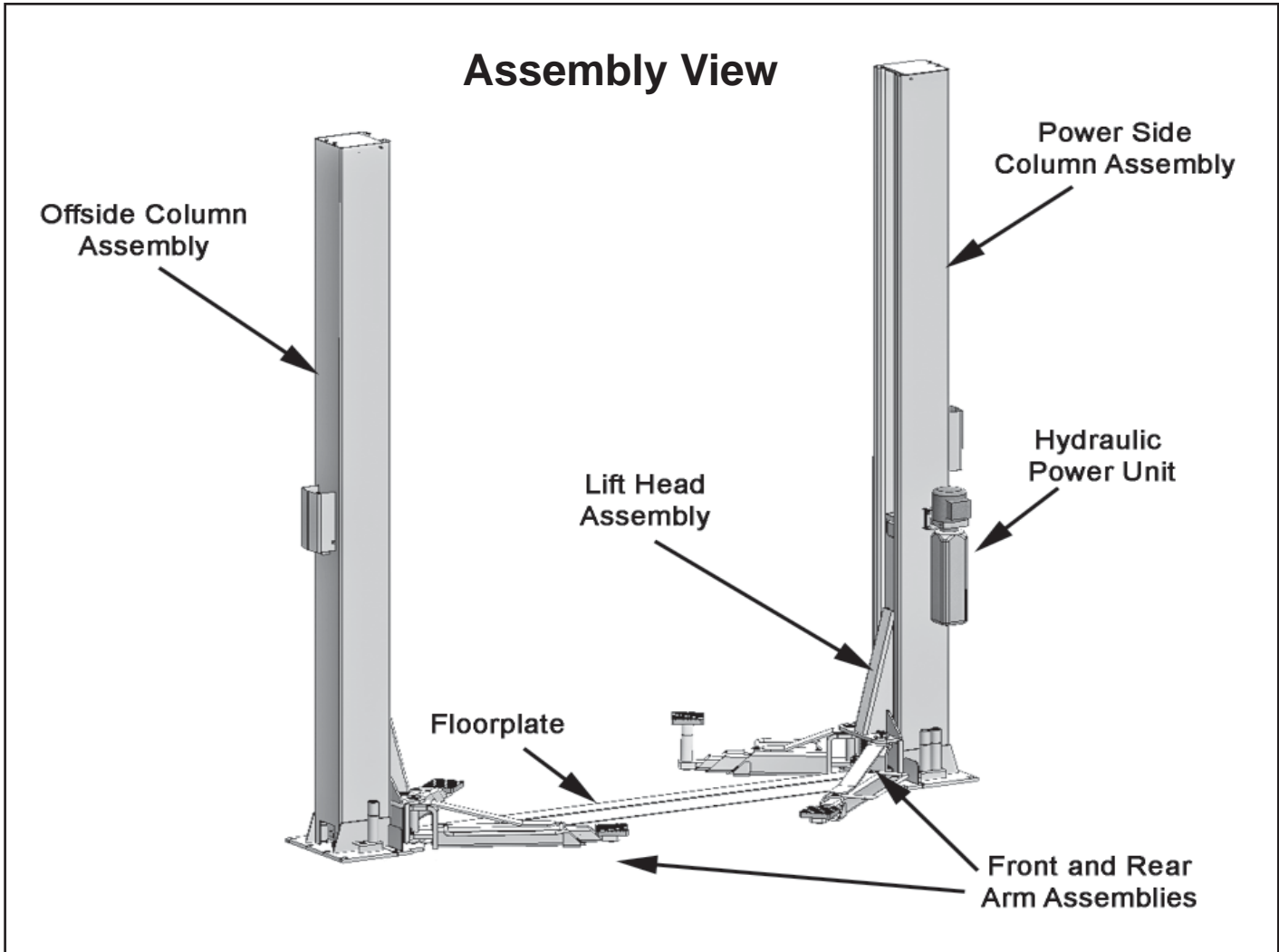

STEP 3

(Column Preparation)

COMPLETE THE FOLLOWING PRIOR TO STANDING UP COLUMNS.

1. Lay the Columns on the floor, slide the Carriage up towards to the top of the Columns just enough to gain access to the Port on the base of the Cylinder. (See Figs. 3.1)

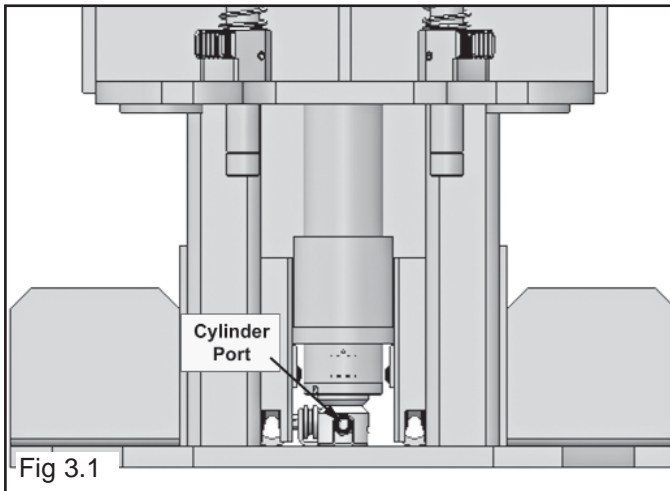

2. Install the Straight 1.4" Straight Fitting into the Cylinder port using Teflon tape on the pipe threads. **DO NOT** use Teflon Tape of the JIC hose Fittings. (See Fig. 3.2)

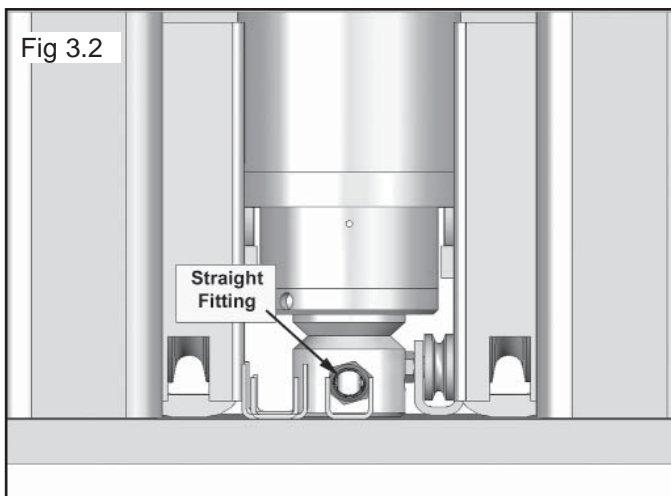

3. Remove Pins, Bottom Sheave Covers, and Sheaves to aid in the routing of the Equalizer Cables.
4. Route Button End of Cable up through Carriage and clip into retaining slot. (See Fig. 3.)

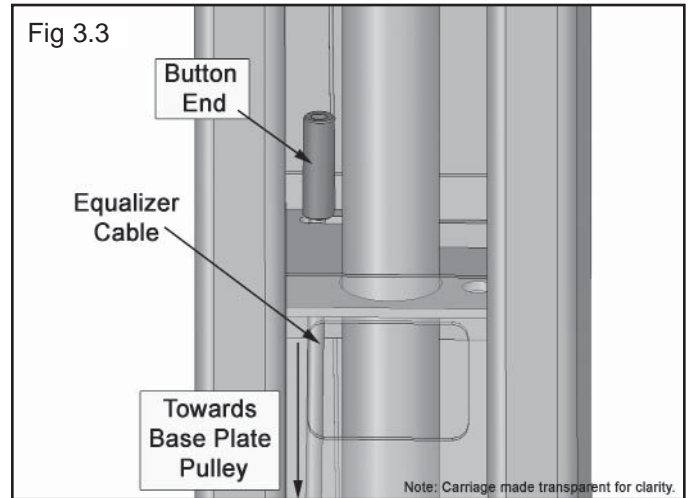

5. Route Threaded end over Sheave (pulley) in the Base plate and reinstall the Sheave and Sheave Cover, and Pin. (See Fig. 3.4)

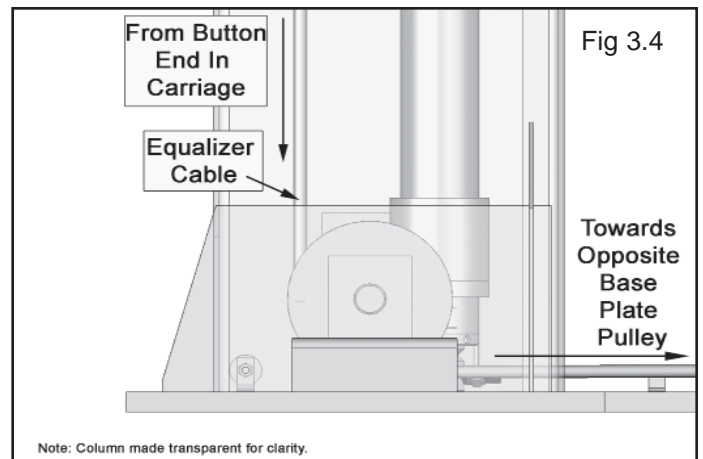

6. Coil Cable and tie or wire to the Carriage. The Threaded End will be routed to the opposite Columns after the Columns are stood up.

Floor Plan / Layout

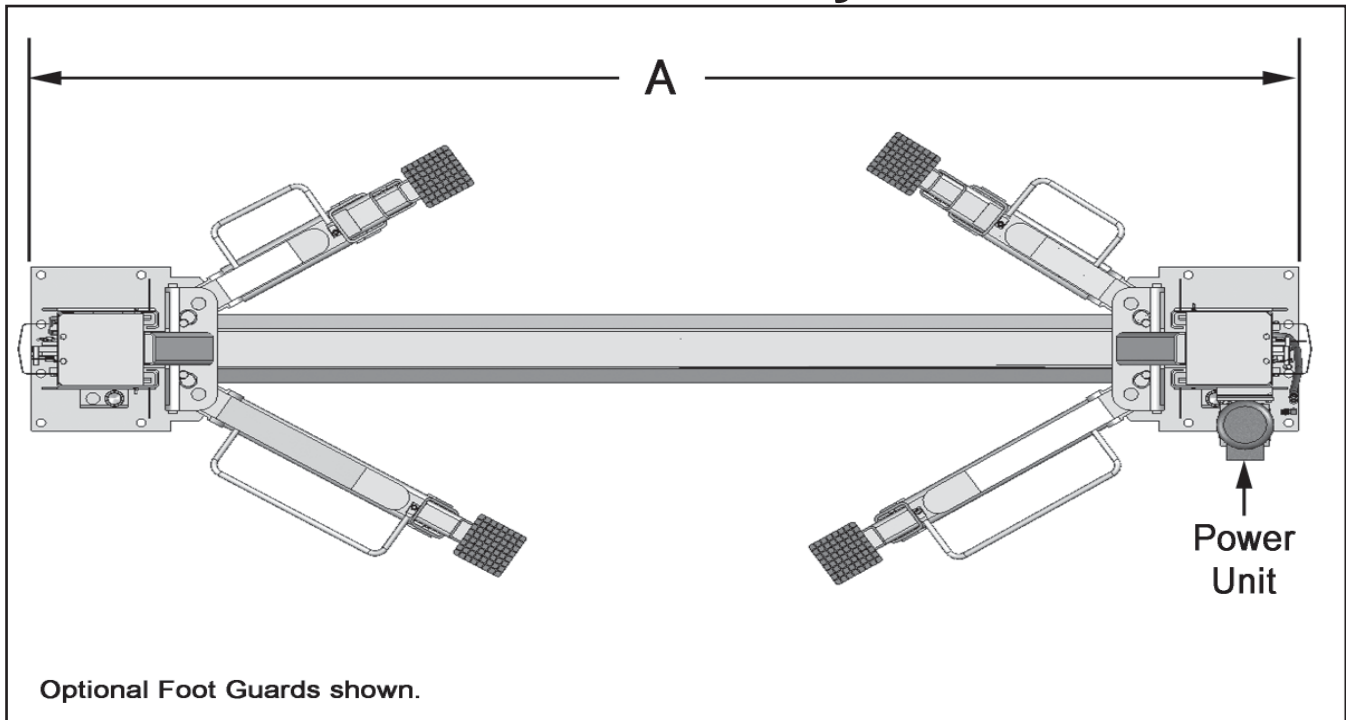

Model	A
XPR-9FD	3353mm / 132"
XPR-9XFD	3683mm / 145"
XPR-12FD	3937mm / 155"

STEP 4 (Site Layout)

1. Determine which side will be the approach side.
2. Now determine which side you prefer the power unit to be located on. The POWERSIDE column has the power-unit mounting bracket attached to the side. (See diagram above for power unit location.)
3. Once a location is determined, use a carpenters chalk line to layout a grid for the Column locations. Keep all dimensions and squareness within 1/8" or malfunctioning of the lift will occur.

4. After the Column locations are properly marked, use a chalk or crayon to make an outline of the Columns on the floor at each location using the Column baseplates as a template.

5. Double check all dimensions and make sure that the layout is perfectly square.

6. Before continuing with the installation it is helpful to stand the Columns up at their respective locations and get a visual of the shop, aisles and other clearances. Also, this is a good time to drive a vehicle into position and check for adequate clearance.

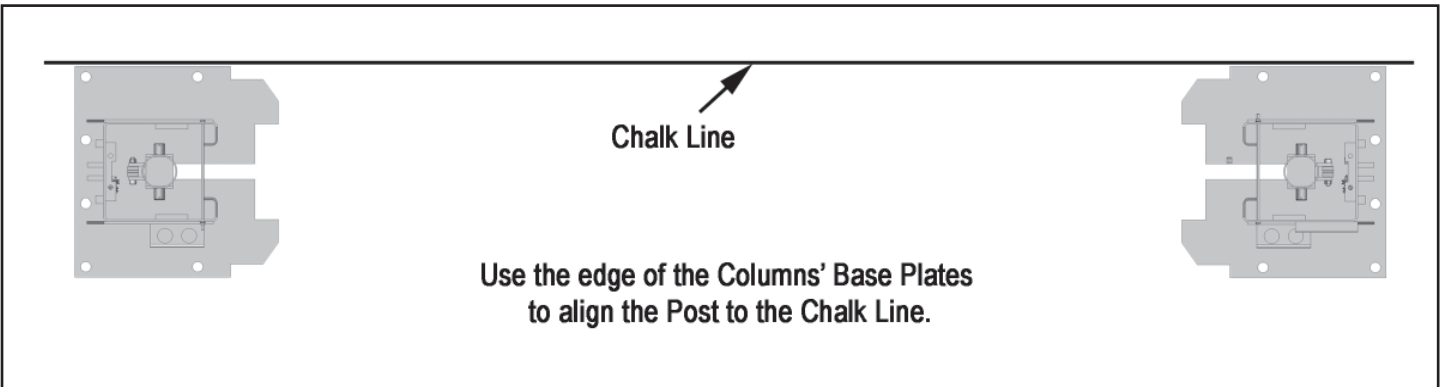

STEP 5

(Installing The POWERSIDE Column)

IMPORTANT NOTE:

BendPak lifts are supplied with installation instructions and concrete fasteners meeting the criteria as prescribed by the American National Standard "Automotive Lifts - Safety Requirements for Construction, Testing, and Validation" ANSI/ALI ALCTV-2006. Lift buyers are responsible for any special regional structural and/or seismic anchoring requirements specified by any other agencies and/or codes such as the Uniform Building Code (UBC) and/or International Building Code (IBC).

1. Before proceeding, double check measurements and make certain that the bases of each Column are square and aligned with the chalk line.

2. Using the baseplate on the POWERSIDE Column as a guide, drill each anchor hole in the concrete approximately (4" deep / 9K models & 6-1/2" deep / 12K models) using a rotary hammer drill and 3/4" concrete drill. To assure full holding power, do not ream the hole or allow drill to wobble. (See Fig. 5.1)

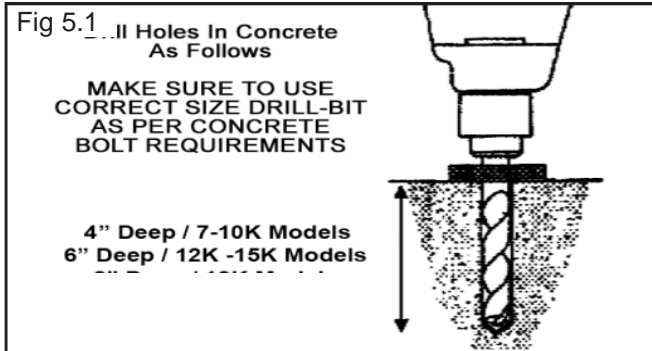

3. After drilling, remove dust thoroughly from each hole using compressed air and/or wire brush. Make certain that the Column remains aligned with the chalk line during this process.

4. Assemble the Washers and Nuts on the anchors then tap into each hole with a hammer until the Washer rests against the baseplate. Be sure that if shimming is required that enough threads are left exposed. (See Fig 5.2)

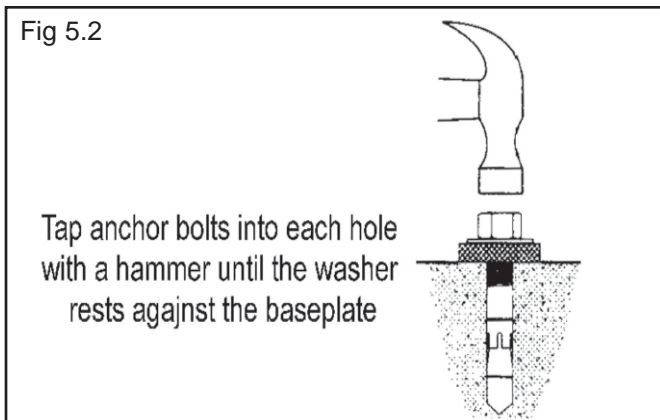

5. If shimming is required, insert the Shims as necessary under the baseplate so that when the Anchor Bolts are tightened, the Columns will be plumb. (See Fig 5.3)

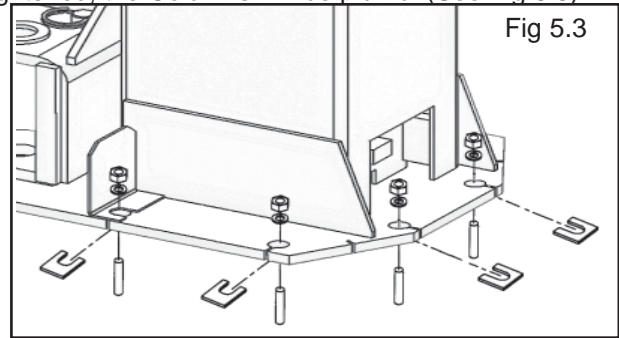

6. If installing the Optional Foot Guards, place the Foot Guards on the Left and right sides as shown (See Fig. 5.4)

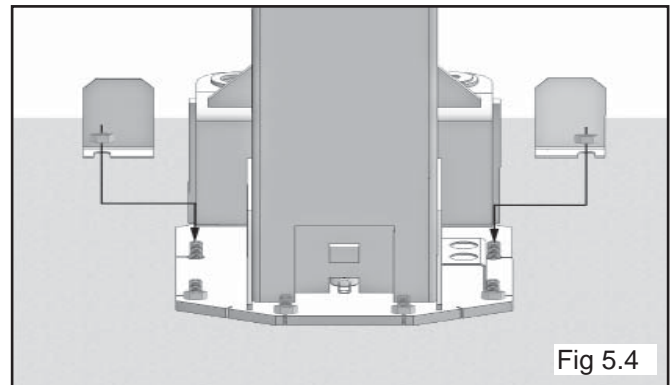

CAUTION !
DO NOT use an impact wrench for this procedure.

7. With the Foot Guards, shims and anchor bolts in place, tighten by securing the nut to the base then turning 3-5 full turns clockwise. **DO NOT** use an impact wrench for this procedure. (See Fig. 5.5)

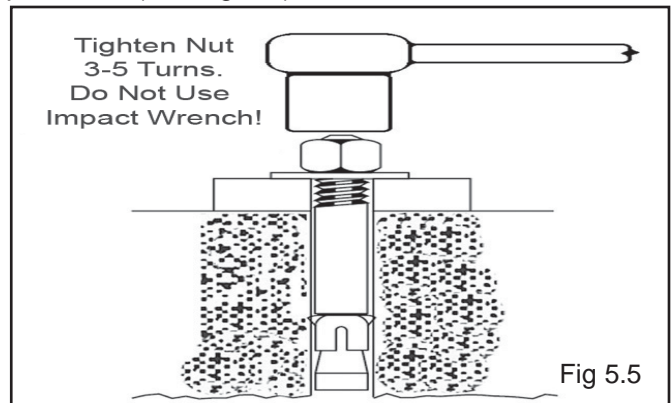

STEP 6

(Installing the Off Side Column)

1. Position the Off Side Column at the designated chalk locations and secure to the floor following the same procedures as outlined in Step 5, Items 1-6.

STEP 7

(Mounting the Hydraulic Power Unit)

1. Attach the Power Unit to the POWERSIDE COLUMN. install the Vibration Dampener between the Power Unit and the Power Unit Mounting plate on the Powerside Column., using four M8 hex bolts and nuts supplied. (See Fig 7.1)

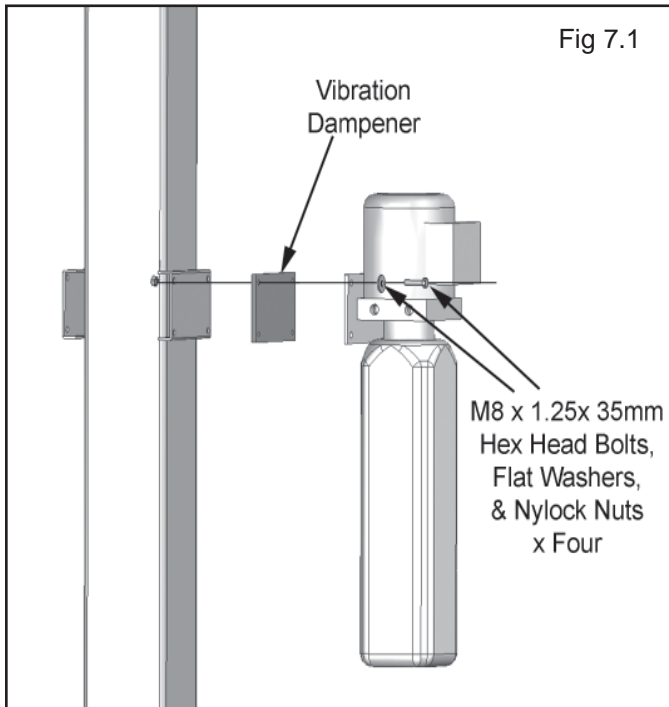

2. Fill the reservoir with 10 WT. HYDRAULIC OIL OR DEXRON TYPE III ATF, approximately four gallons. Make sure the funnel used to fill the power unit is clean.

Do not connect Power Unit Hydraulic Hose Assy. at this time.



DANGER !
ALL WIRING MUST BE PERFORMED
BY A LICENSED ELECTRICIAN.



DANGER!
DO NOT PERFORM ANY MAINTENANCE OR
INSTALLATION OF ANY COMPONENTS WITH OUT
FIRST ENSURING THAT ELECTRICAL POWER HAS
BEEN DISCONNECTED AT THE SOURCE OR PANEL
AND CANNOT BE RE-ENERGIZED UNTIL ALL
MAINTENANCE AND/OR INSTALLATION
PROCEDURES ARE COMPLETED.

3. The standard Power Unit for your lift is 220 volt, 60HZ, single phase. All wiring must be performed by a certified electrician only. SEE WIRING INSTRUCTIONS AFFIXED TO MOTOR FOR PROPER WIRING INSTRUCTIONS



- ◆ DO NOT run power unit with no oil. Damage to pump can occur.
- ◆ The power unit must be kept dry. Damage to power unit caused by water or other liquids such as detergents, acid etc., is not covered under warranty.
 - ◆ Operate lift only between temperatures of 41 ° - 104° F.
- ◆ Improper electrical hook-up can damage motor and will not be covered under warranty.
 - ◆ Motor can not run on 50HZ without a physical change in motor.
 - ◆ Use a separate breaker for each power unit.
 - ◆ Protect each circuit with time delay fuse or circuit breaker.
 - ◆ For 208-230 volt, single phase, use a 25 amp fuse.
 - ◆ For 208-230 volt, three phase, use a 20 amp fuse.
 - ◆ For 380-440 volt, three phase, use a 15 amp fuse.

STEP 8

(Installing the Safeties and Safety Cable)

1. Install Safety Weldments into each respective Column. (See Figs 8.1 & 8. 2.)

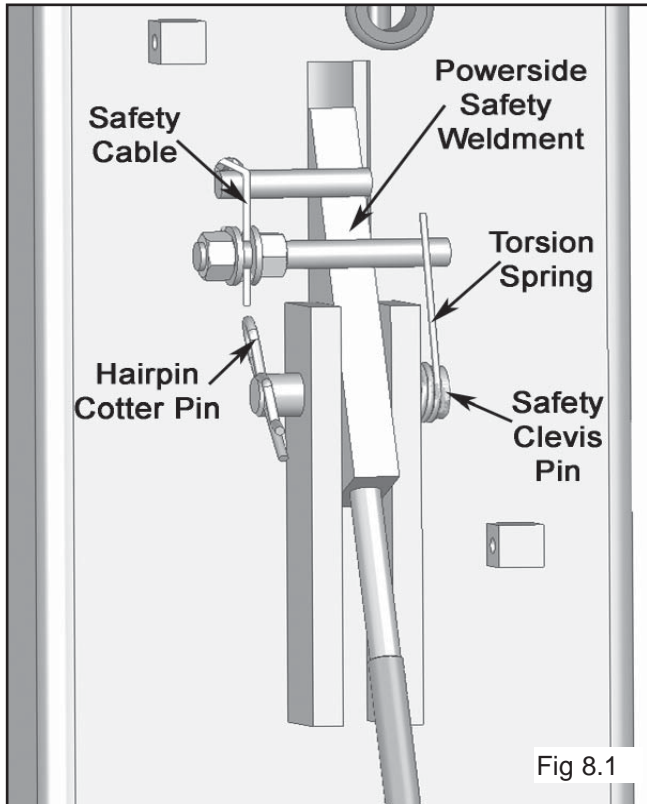

2. From the Offside Column insert the non looped end of the Safety Cable through the hole located to the right of the Offside Safety Weldment. (See Fig 8.3)

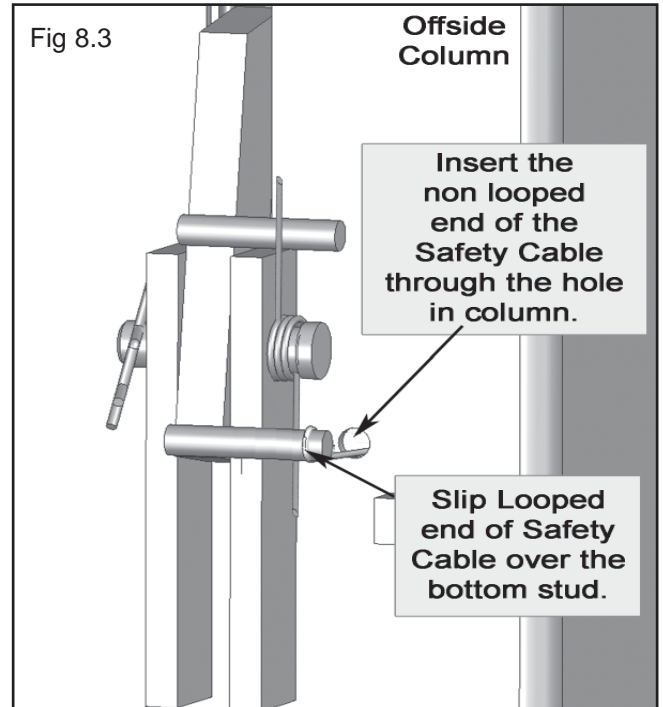

3. Route the Cable over the Safety Cable Pulley and take it down to the Base Plate Pulley. (See Fig 8.4)

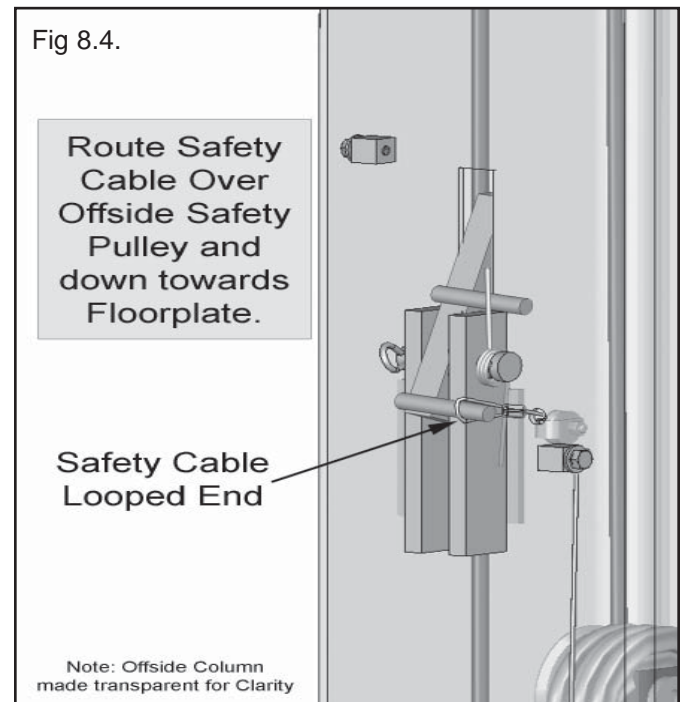
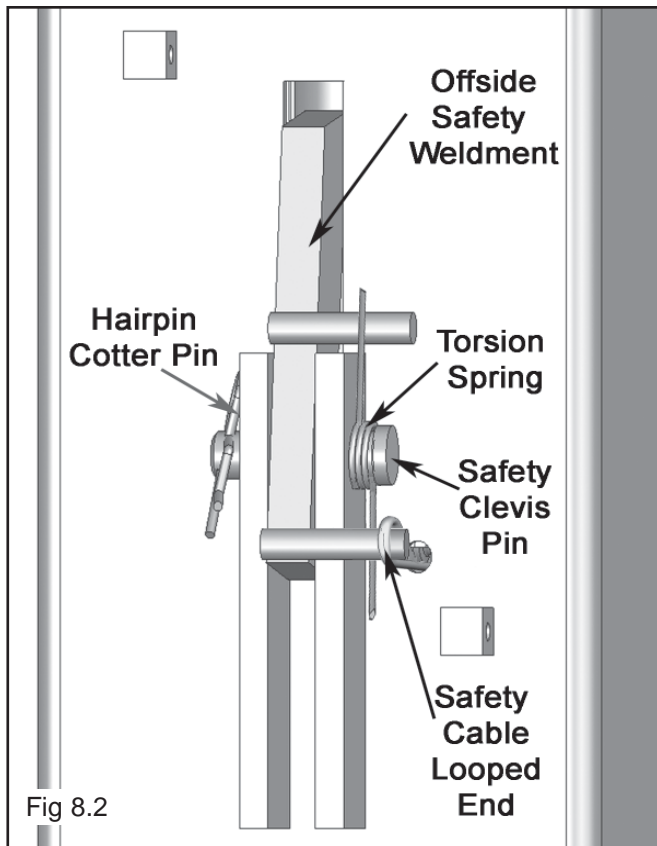

4. Route the Safety Cable through the Base Plate Safety Cable Pulley(s) and across the floor towards the Powerside Columns. (See Figs 8.5 & 8.6)

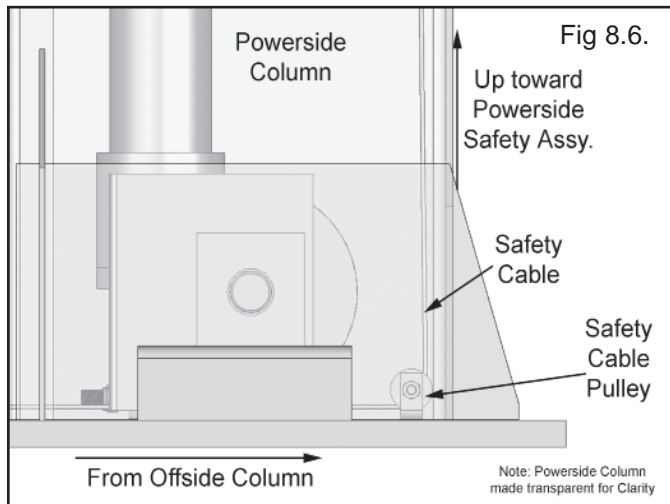
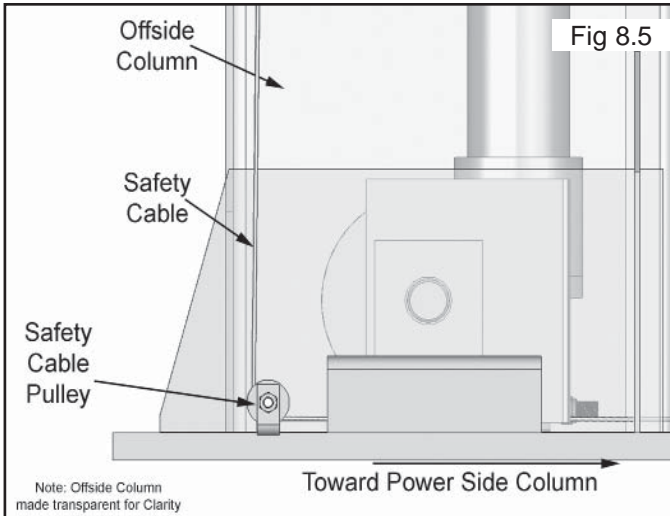

5. Route the Safety Cable up the Power Side Post going towards the Power Side Safety Cable Pulley.

6. Route the Safety Cable over the Power Side Safety Cable Pulley, through the hole in the Column and over the top pin on the Safety Handle. Insert the Cable end through the hole on the threaded Pin. (See Fig 8.7)

7. Pull the slack out the Safety Cable and hold tension as the Cable is being tightened.. Tighten Jam Nuts on either side of the Cable to secure it into place. (See Fig 8.7)

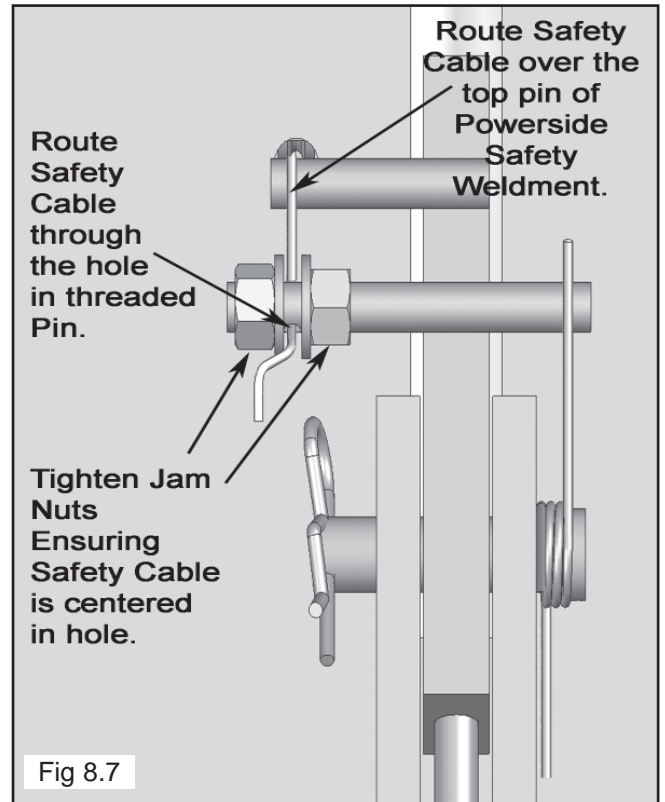

8. Operate the Power Side Safety handle, check for Proper Operation of both Safety Assemblies and adjust Cable tension as required.



DANGER !
ENSURE THAT BOTH THE POWERSIDE & OFFSIDE SAFETIES ENGAGE PROPERLY PRIOR TO LIFT OPERATION.

9. Raise and lock each carriage approximately 28" above the ground. (See Fig. 8.8)

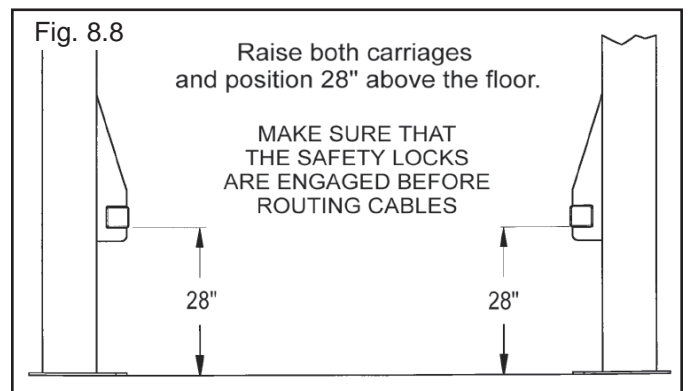

CAUTION!
Make sure to tighten both nuts equally so as to keep the safety cable centered

STEP 9

(Installing The Hydraulic Lines)

1. Connect the two Cylinder Hydraulic Hoses in line to the Tee Fitting. Connect the 90° Fitting to the Tee Fitting. Connect the Power Unit Hose to the 90° Fitting. (See Fig 9.1)

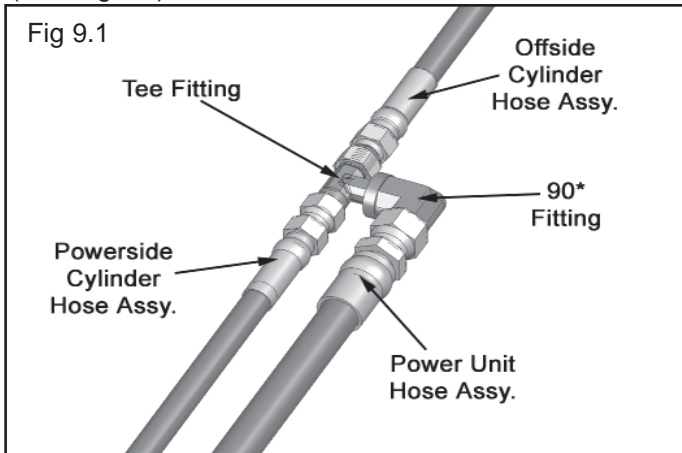

2. Connect the Cylinder Hoses to the Straight Fittings on the Cylinders. DO NOT use Teflon Tape on the JIC Fittings. (See Fig 9.2)

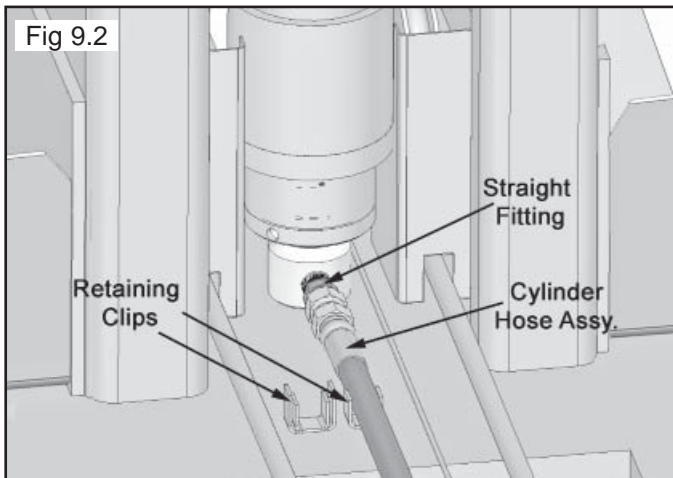

WARNING !

When routing Hydraulic Hoses through the Columns, route Hoses through the retaining rings welded on each Column. Make sure that the Hose is clear of any moving parts. It may be necessary to tie Hose clear by using nylon tie straps or wire. Failure to keep Hydraulic Hoses clear may result in Hydraulic Hose failure which may result in damage or personal harm.

3. Route the Power Unit Hose between the Cylinder Shaft and the Equalizer Pulley Bracket. Route the Hose through the retaining rings. Failure to do so may cause damage or injury. (See Fig 9.3)

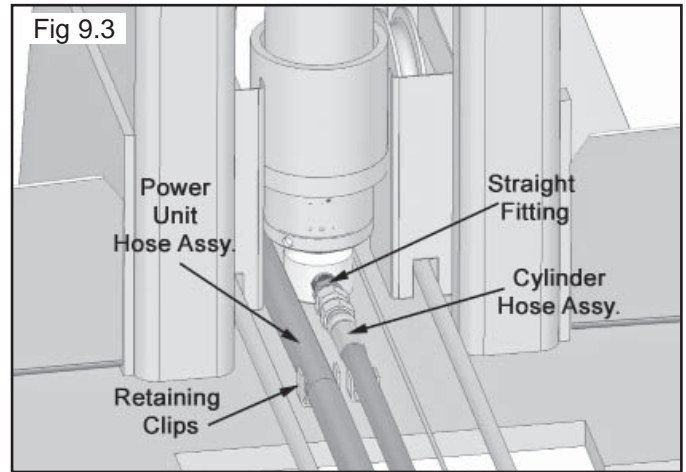

NOTE:

Location of Power Port in Hydraulic Unit may vary. Confirm Location of Power Port on Power Unit Documentation.

4. Remove the plastic plug from the Power Unit Power Port. Install the 90° Power Unit Fitting with O-Ring using Teflon tape. (Connect the Power Unit Hose Assembly to the 90° Hydraulic Fitting on the Power Unit. DO NOT use Teflon tape on the JIC Hose fittings. (See Fig 9.4)

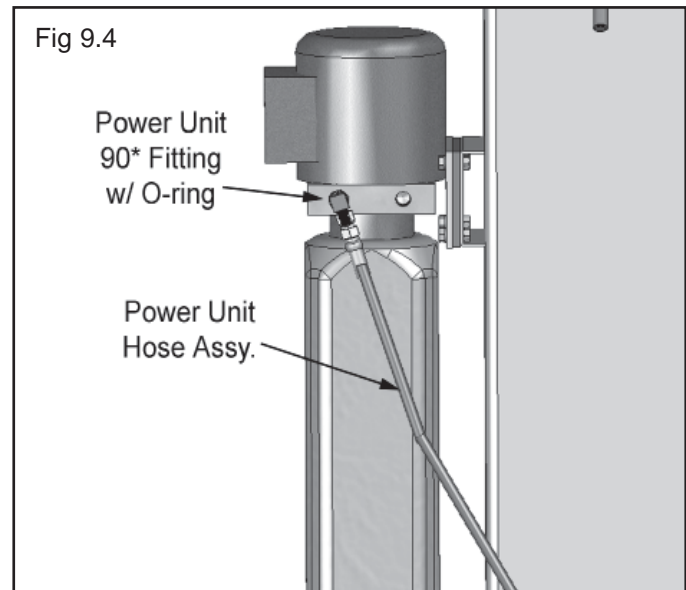

STEP 10

(Routing The EQUALIZER CABLES)

1. With the Carriages raised equal height off the floor, route the Equalizer Cables. (See Fig. 10.1)

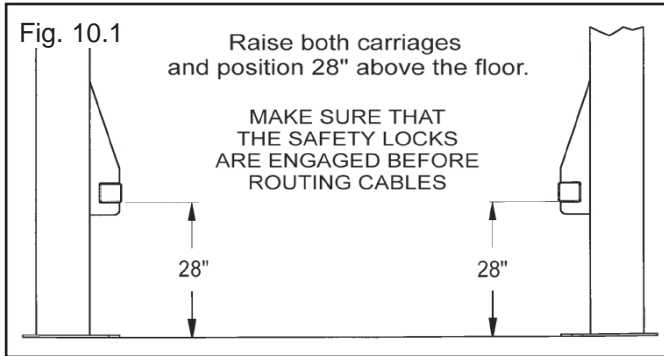

DANGER !

Make sure that the Safety Locks on each column are fully engaged before attempting to route Equalizer Cables and/or hoses. Carriages must be equal height from the floor before proceeding.



WARNING!

WHEN THE CABLE ADJUSTING NUTS BOTTOM OUT ON THE THREADED END OF THE CABLE CONNECTOR AND THERE IS STILL SLACK IN THE CABLES, THE CABLES HAVE STRETCHED BEYOND THE SAFE USEFUL LENGTH AND NEED TO BE REPLACED WITH FACTORY APPROVED CABLE ASSEMBLIES. DO NOT PLACE WASHERS, SPACERS OR OTHER DEVICES TO "SHORTEN" THE EFFECTIVE CABLE LENGTH AS DAMAGE TO THE LIFT OR INJURY TO PERSONS MAY OCCUR.



WARNING !

The Equalizer Cable Pulleys will need to be removed to ease the routing of the Equalizer Cables. Be sure to reinstall all pins, covers and clips or serious damage or injury may occur.

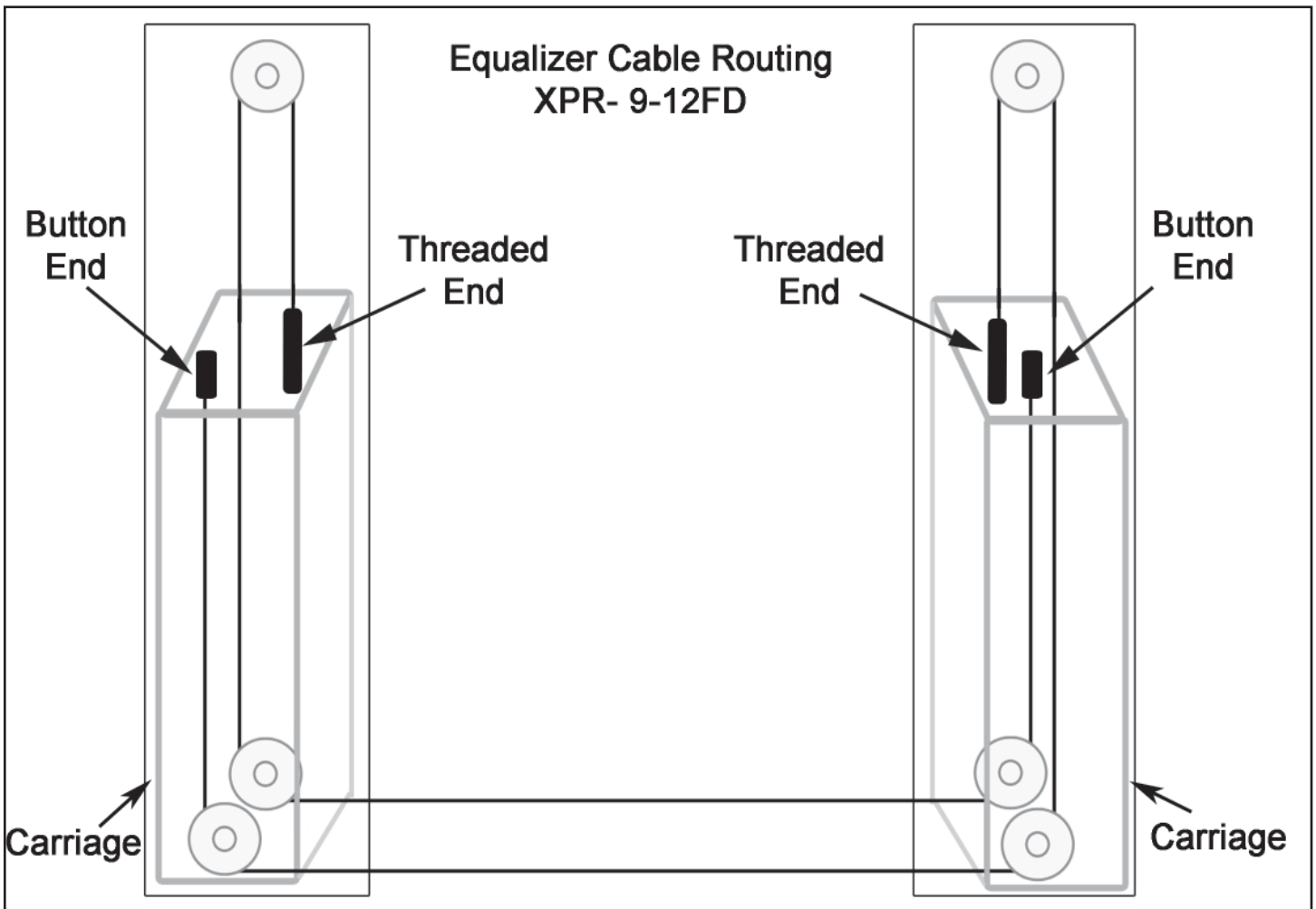

3. Route the Threaded End of the Equalizer Cable across to the opposite side Base Plate Sheave(pulley) and up through the Carriage. (See Fig. 10.2)

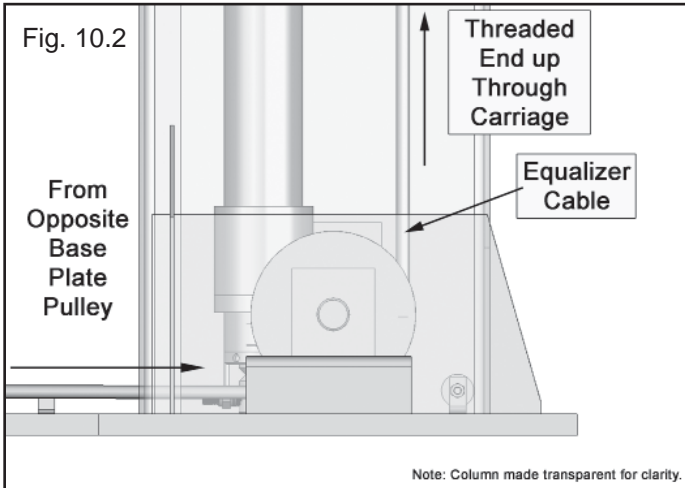

4. Route the Threaded end up and over the Top Plate Pulley and back down to the Carriage. (See Fig. 10.3)

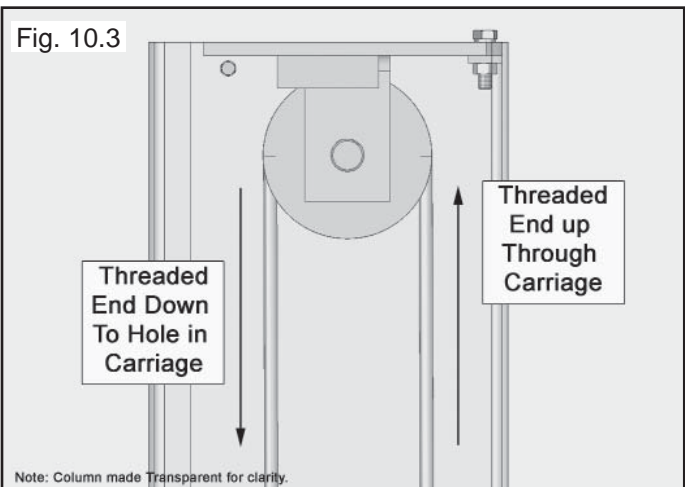

5. Run the Threaded End through the hole in the top of the Carriage and secure with the Hex Head Nut until the Cable is just taut. (See Fig. 10.4)

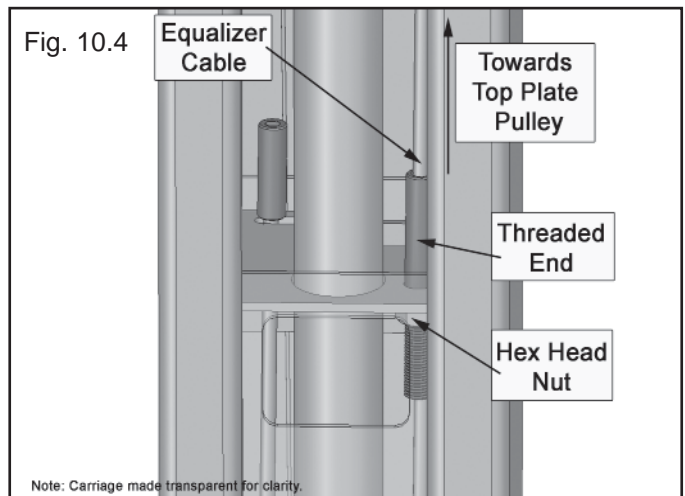

STEP 11

(Installing Powerside and Offside Safety Cover)

1. After Safeties have been adjusted and checked for proper operation, install and tighten Powerside Safety Cover and Offside Safety Cover mounting Bolts. (See Fig. 11.1 and 11.2)

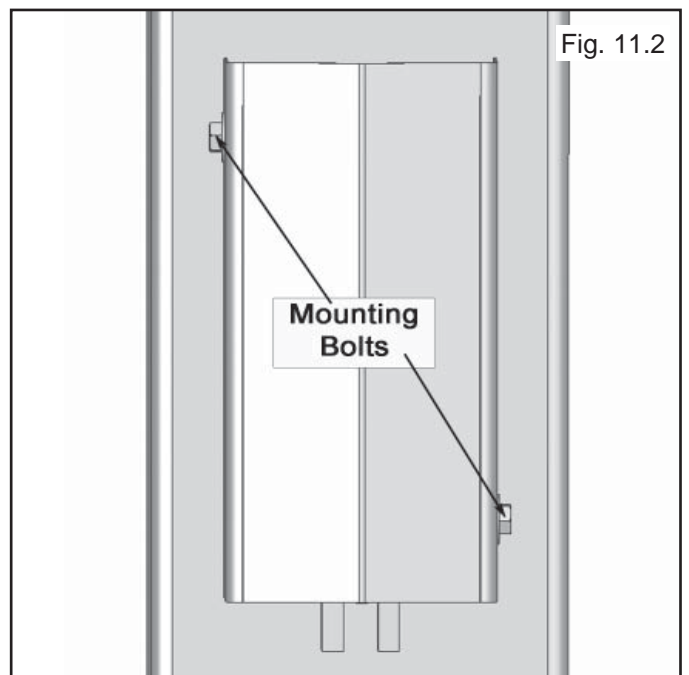
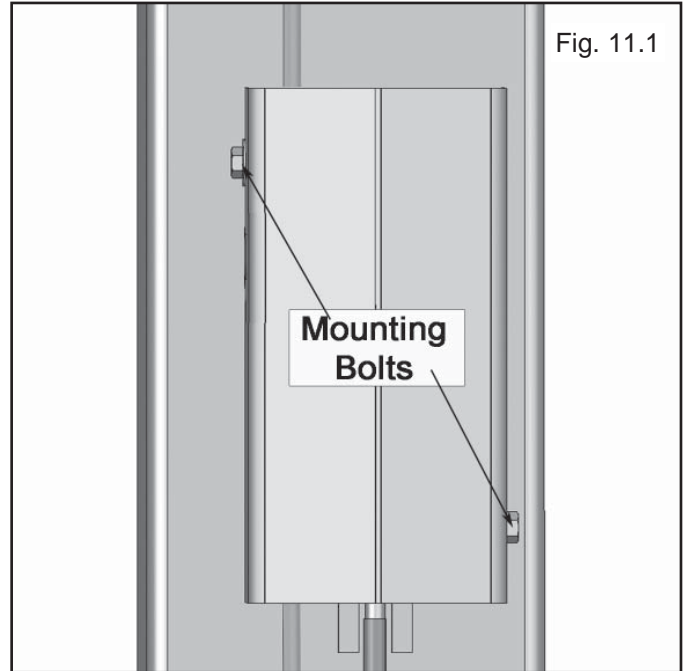

STEP 12

(Installing the Lift Arms)

1. Place the appropriate Lift Arm Assy on the Lift Heads.
(See Fig. 12.3- 12.4)

2. Install the Left Head Pins into the Lift Head and through the holes in the Arm Assy. (See Fig. 12.1)

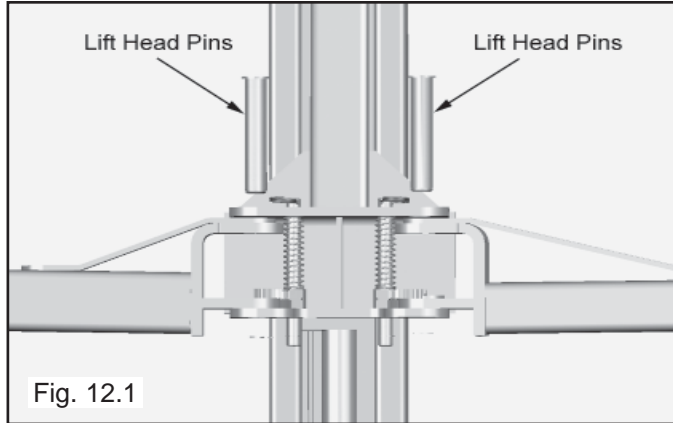

3. Install the Snap Ring into the groove in the Lift Head Pin the under side of the Lift Head. (See Fig. 12.2)

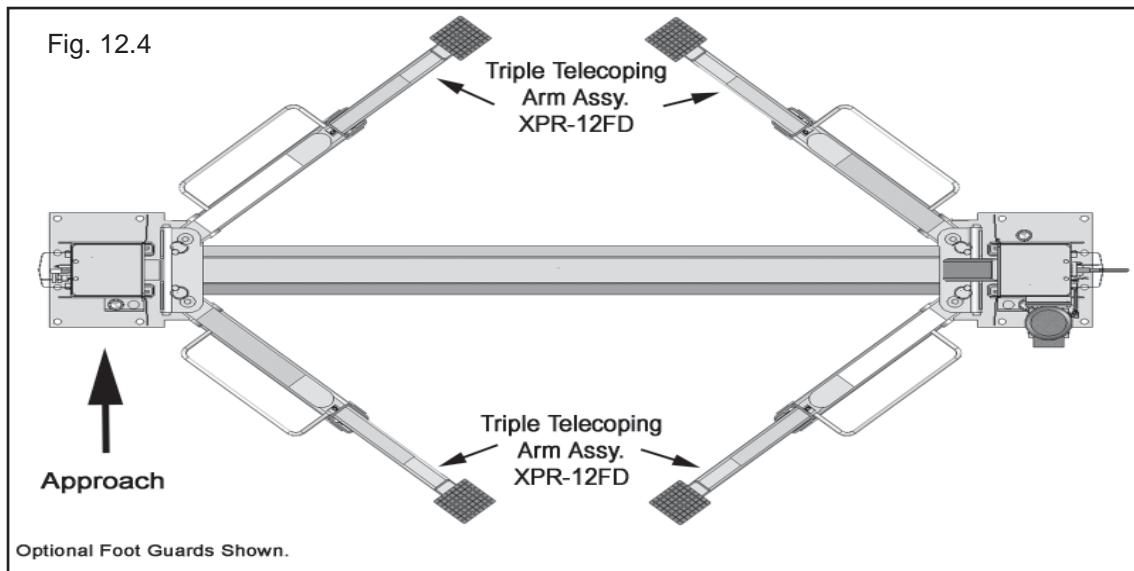
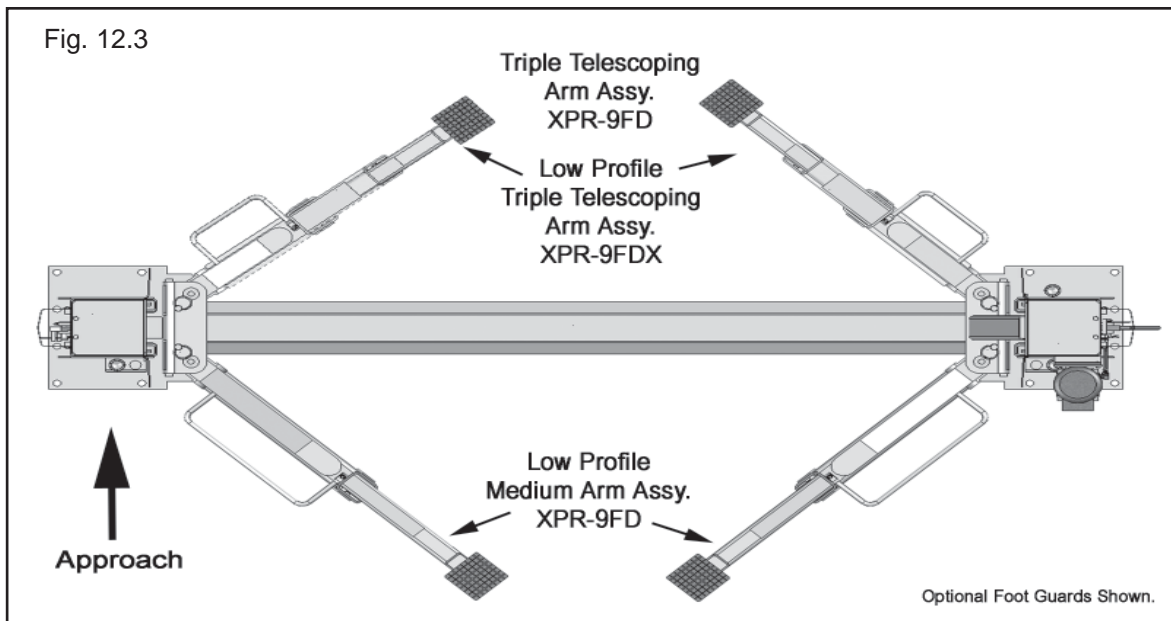
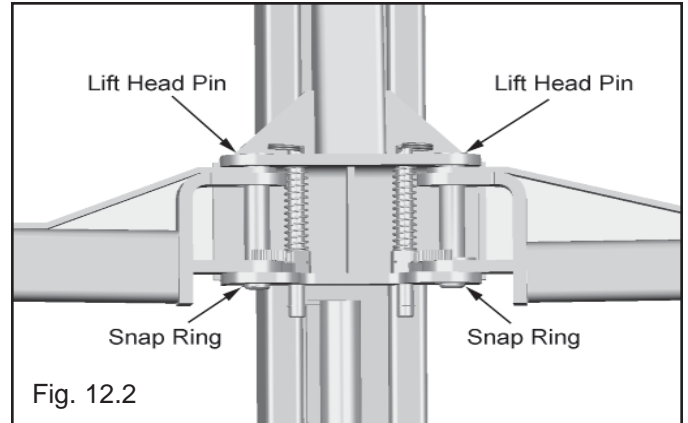

⚠ DANGER

DANGER!
 The Arm Restraint Gears must be properly positioned and adjusted. Confirmation that the gears are engaging properly must be made prior to operating the lift. Periodic inspection and adjustment is required. Failure to inspect and adjust the arm restraint assemblies on all four arms can result in damage to the vehicle or injury and or death.

4. Each Arm Restraint Gear can be oriented in a Left or Right configuration on the Arms. Each Arm and Arm Restraint Gear must be positioned in the proper location on the Lift Head. (See Fig. 12.5 & 12.6)

NOTE:
Left and Right are determined when facing the inside/open side of the Lift Column.

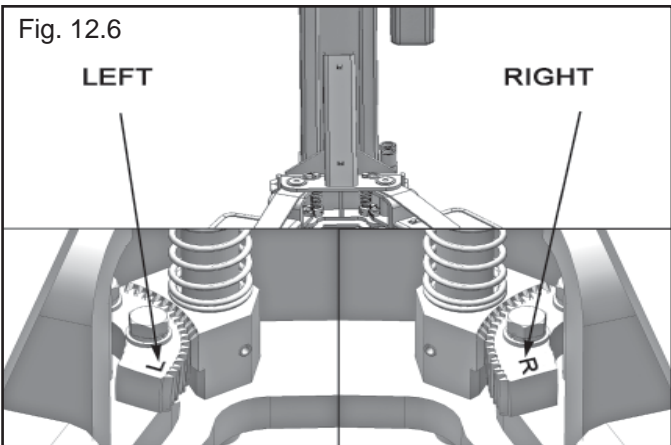
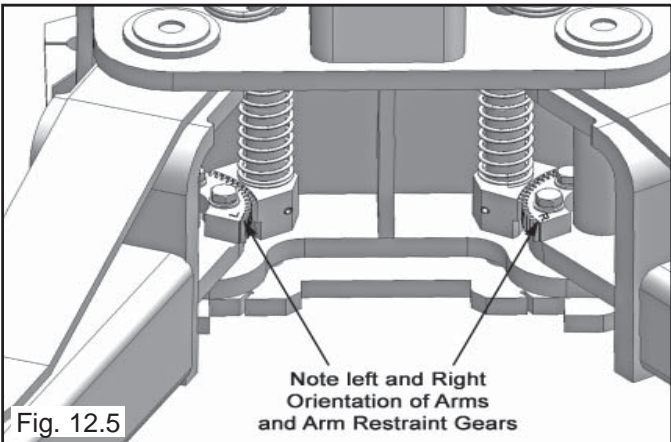

5. Loosen the Arm Restraint Gear Ring Bolts and adjust the Arm Restraint Gears so that the Teeth on the Gear Ring mesh smoothly with the teeth on the gears of the Arm Restraint Pin. (See Fig. 12.7)

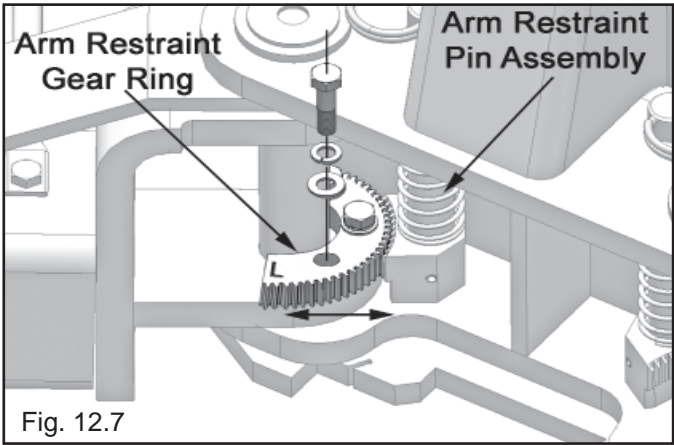

6. Tighten the Gear Ring bolts.
 7. Verify the operation of the Arm restraints by pulling up on the Key Ring of the Arm Restraint Pin. Pivot the arms back and forth and test the operation of the Arm Restraint Pin in various positions. When releasing the Arm Restraint Pin the Pin should drop and the Gears should engage. (See Fig. 12.8)

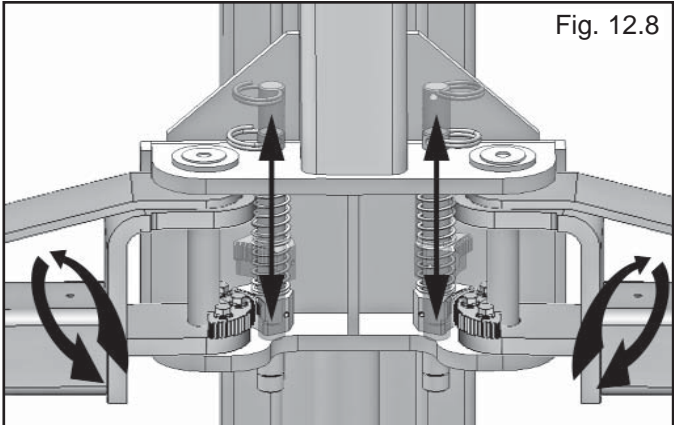

8. Ensure that the Arms do not move when a force of approximately 100 pounds or less is applied laterally to the fully extended arms.
 9. Adjust the Gear ring on the Arm as necessary to ensure smooth operation and solid engagement of all four Arm Restraint Pin Assemblies with the Arm Restraint Gear Ring.

⚠ DANGER

EACH ARM RESTRAINT ASSEMBLY MUST BE INSPECTED AND ADJUSTED AS NEEDED BEFORE EACH AND EVERY TIME THE LIFT IS OPERATED.

DO NOT OPERATE THE LIFT IF ANY OF THE FOUR ARM RESTRAINT SYSTEMS ARE NOT FUNCTIONING PROPERLY.

REPLACE ANY BROKEN COMPONENTS OR COMPONENTS WITH BROKEN TEETH ONLY WITH AUTHORIZED OR APPROVED REPLACEMENT PARTS.

WARNING

IMPORTANT LEVELING INSTRUCTIONS

Before operating your lift, check to make sure that both "A" and "B" measurements are EQUAL.

The lift arms must be level before operation.

If your lift arms are not level, shim the columns as required.

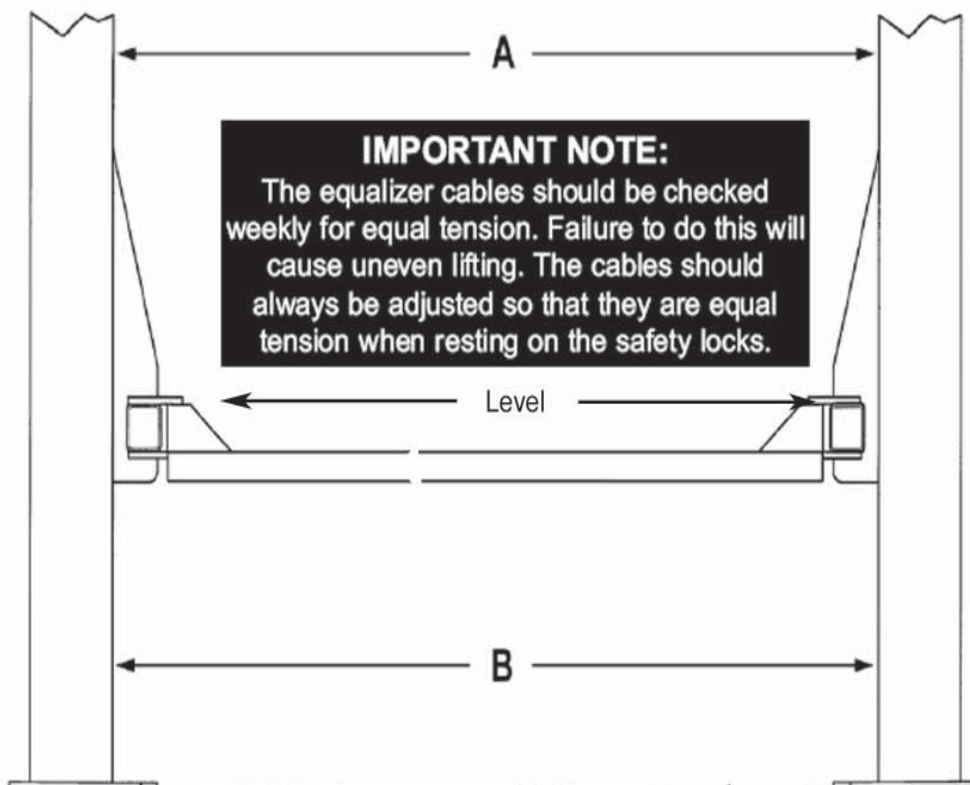

⚠ WARNING

You **MUST** re-install top carriage-stop bolt (shown below) after top beam/plate is installed and secured. Tighten carriage-stop bolt to 2-3 ft. lbs. of torque upon final installation inspection. These instructions must be followed to insure proper installation and operation of your lift. Failure to comply with these instructions can result in serious bodily injury and or death and or void product warranty. Manufacturer will assume no liability for loss or damage of any kind, expressed or implied resulting from improper installation or use of this product.

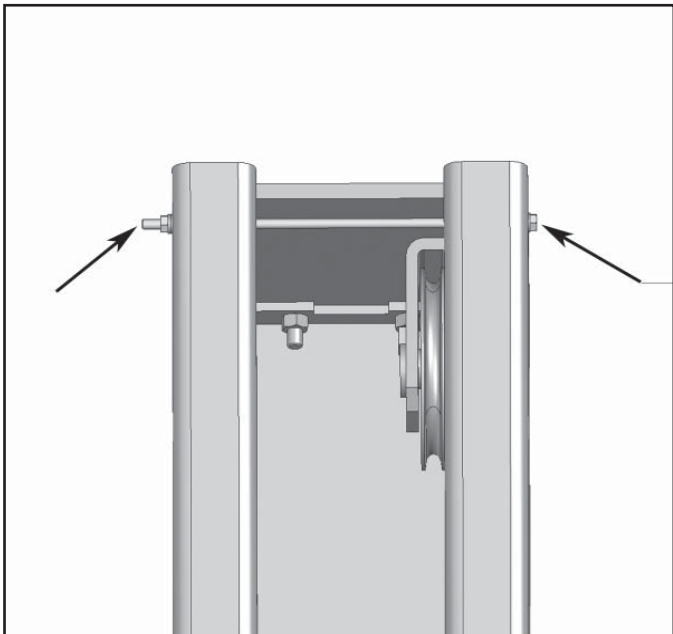
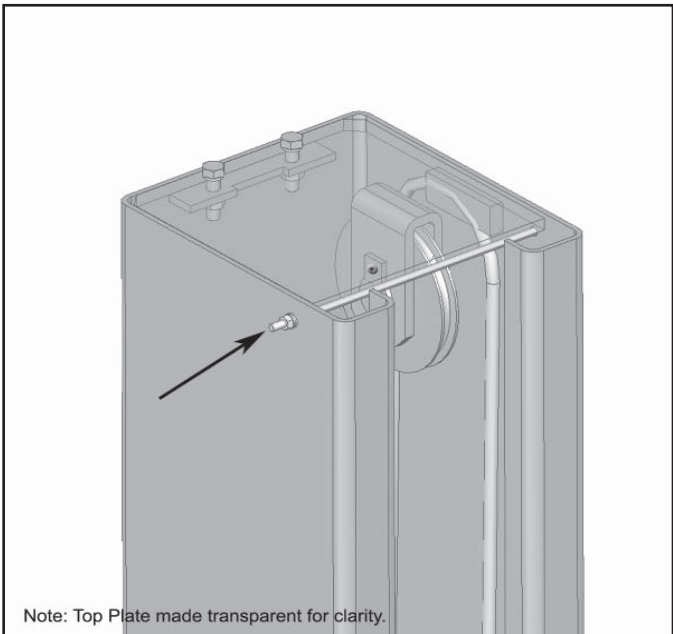
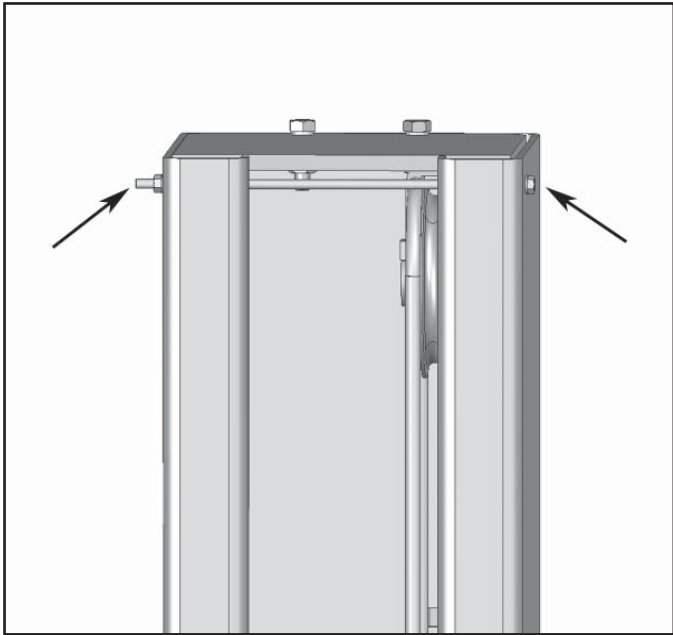
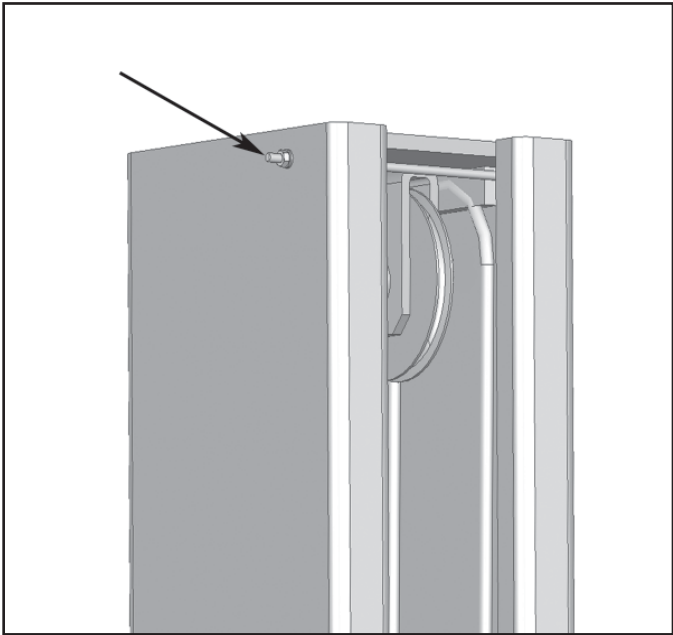



DANGER!

DO NOT PERFORM ANY MAINTENANCE OR INSTALLATION OF ANY COMPONENTS WITH OUT FIRST ENSURING THAT ELECTRICAL POWER HAS BEEN DISCONNECTED AT THE SOURCE OR PANEL AND CANNOT BE RE-ENERGIZED UNTIL ALL MAINTENANCE AND/OR INSTALLATION PROCEDURES ARE COMPLETED.



IMPORTANT POWER-UNIT INSTALLATION NOTES

- DO NOT run power unit with no oil. Damage to pump can occur.
- The power unit must be kept dry. Damage to power unit caused by water or other liquids such as detergents, acid etc., is not covered under warranty.
- Improper electrical hook-up can damage motor and will not be covered under warranty.
- Motor can not run on 50HZ without a physical change in motor.
- Use a separate breaker for each power unit.
- Protect each circuit with time delay fuse or circuit breaker.
- For 208-230 volt, single phase, use a 25 amp fuse.
- For 208-230 volt, three phase, use a 20 amp fuse.
- For 380-440 volt, three phase, use a 15 amp fuse.

Installation and adjustment.

DO NOT attempt to raise vehicle until a thorough operation check has been completed.

All wiring must be performed by a certified electrician only.

Single Phase

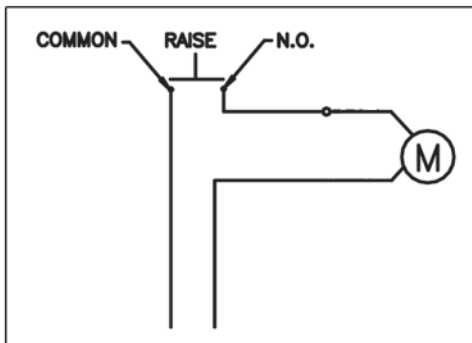

Three Phase

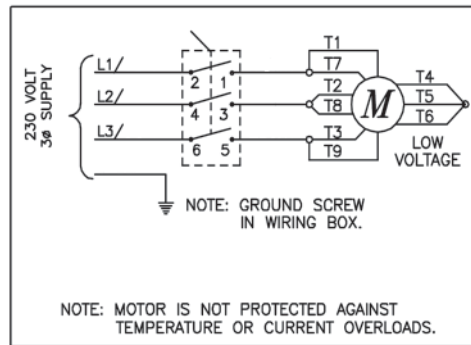

SEE WIRING INSTRUCTIONS AFFIXED TO MOTOR FOR PROPER WIRING INSTRUCTIONS.

TWO-POST LIFT POWER SIDE POST SAFETY LABEL PLACEMENT GUIDELINES



WARNING!

THESE ANSI/ALI ALCTV-2006 MANDATED SAFETY LABELS ARE PROVIDED FOR THIS PRODUCT FOR THE PROTECTION OF THE OPERATOR AND ANY PERSON(S) WORKING NEAR THE LIFT. THE SAFETY STICKERS MUST BE INSTALLED AS PER THE INSTRUCTIONS BELOW, PRIOR TO THE COMPLETION OF INSTALLATION.

FAILURE TO PROPERLY INSTALL WARNING LABELS COULD FAIL TO WARN AND LEAD TO SERIOUS PERSONAL INJURY OR DEATH TO OPERATOR OR BYSTANDER OR DAMAGE TO PROPERTY. BE SURE EVERYONE WHO OPERATES THIS EQUIPMENT UNDERSTANDS ALL THE INFORMATION, CAUTION, WARNING, AND DANGER LABELS. KEEP ALL LABELS CLEAN SO THEY ARE LEGIBLE. THIS APPLIES TO ALL CAUTION, WARNING, AND DANGER LABELS. IT IS THE OWNER'S RESPONSIBILITY TO PROVIDE INFORMATION TO ALL OPERATORS FOR SAFE OPERATION OF THIS LIFT. REPLACE ANY DAMAGED OR WORN LABELS. ONCE ANY PART OF A LABEL BECOMES ILLEGIBLE, IT SHOULD BE REPLACED. THE PART NUMBERS FOR THE LABELS ARE LOCATED IN THE LOWER RIGHT CORNER OF THE LABEL. REPLACEMENT LABELS MAY BE ORDERED THROUGH YOUR DEALER OR THE ADDRESS BELOW. WHEN INSTALLING AND/OR REPLACING LABELS, BE SURE THE SURFACE IS CLEAN AND DRY, PEEL THE BACKING OFF THE LABEL, AND APPLY TO THE POST AS SHOWN BELOW. BE SURE TO WIPE WITH A CLEAN CLOTH TO RUB OUT ALL AIR BUBBLES.

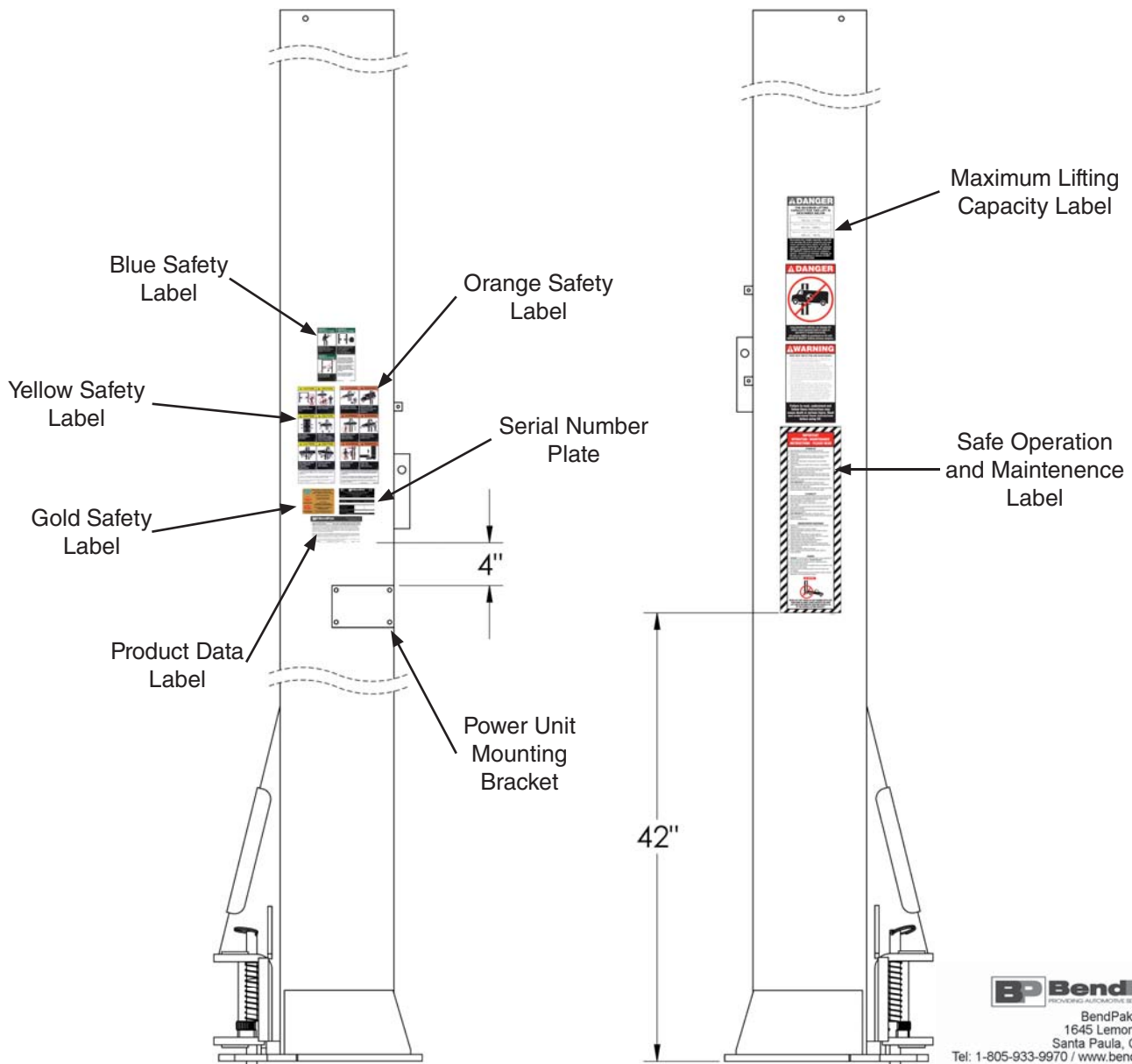

STEP 13

(Power Unit Hook Up)

1. Have a certified electrician run the power supply to motor. Refer to the data plate found on the motor for proper power supply and wire size.



RISK OF EXPLOSION!

This equipment has internal arcing or parts that may spark and should not be exposed to flammable vapors. Motor should not be located in a recessed area or below floor level. NEVER expose motor to rain or other damp environments. **DAMAGE TO MOTOR CAUSED BY WATER IS NOT COVERED UNDER WARRANTY.**

IMPORTANT NOTE:

CAUTION Never operate the motor on line voltage less than 208V. Motor damage may occur which is not covered under warranty. Have a certified electrician run appropriate power supply to motor. Size wire for 25 amp circuit. See Motor Operating Data Table.

IMPORTANT: Use separate circuit for each power unit. Protect each circuit with time delay fuse or circuit breaker. For single phase 208-230V, use 25 amp fuse. Three phase 208-240V, use 25 amp fuse. For three phase 400V and above, use 15 amp fuse. All wiring must comply with NECK and all local electrical codes.

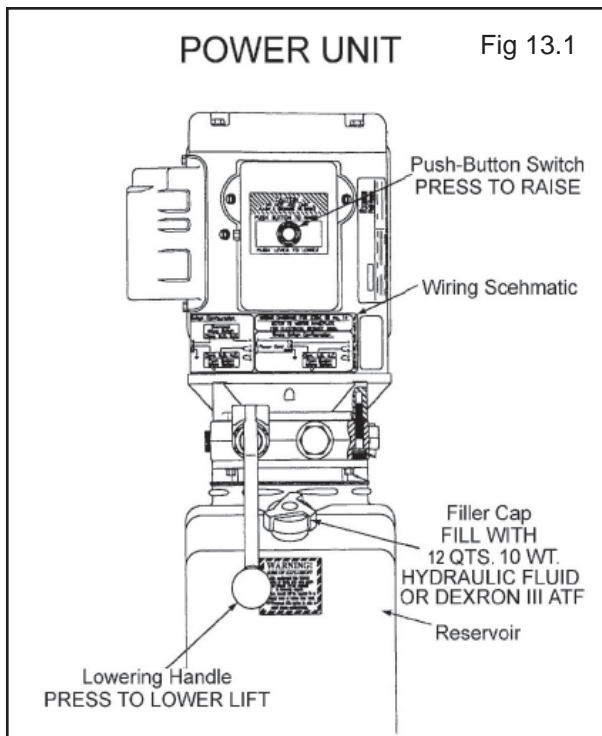

Typical Power Unit shown controls and labels may vary.

STEP 14

(Lift Start Up / Final Adjustments)



CAUTION!

During the START-UP procedure, observe all operating components and check for proper installation and adjustment. **DO NOT** attempt to raise vehicle until a thorough operational check has been completed.

1. Make sure the Power Unit reservoir is full with 12 quarts of 10-WT hydraulic oil or Dexron-III automatic transmission fluid.
2. Spray the inside of the Columns where the Slide Blocks glide with a light lubricant or WD-40.
3. Test the Power Unit by pressing the push-button switch. If the motor sounds like it is operating properly, raise the lift and check all Hose connections for leaks. If the motor gets hot or sounds peculiar, stop and check all electrical connections.
4. Before proceeding, double-check to make sure all Cables are properly positioned within the grooves of ALL Sheaves / Pulleys. Make sure all Cable Sheave retaining Pins and/or Clips are secure.
5. Check to make sure that all Safety Locks are cleared and free.
6. Continue pressing the raise button until the Cables get taugted and the lift starts to move.
7. **KEEP HANDS AND FEET CLEAR.** Remove hands and feet from any moving parts. Keep feet clear of lift when lowering. Avoid pinch points.
8. Check all MAIN SAFETY LOCKS to make sure they move freely and spring back to the lock position when released. Lubricate all SAFETY PIVOT points with WD-40 or equal.
9. Run the lift up and down a few times to insure that the locks are engaging uniformly and that the safety release mechanisms are functioning. Re-adjust if necessary.

POST-INSTALLATION CHECK-OFF

- Columns Properly Shimmed And Stable
- Anchor Bolts Tightened
- Pivot / Sheave Pins Properly Attached
- Carriage Stop bolts Torqued to 2-3 Ft. Lbs
- Electric Power Supply Confirmed
- Cables Adjusted Properly
- Safety Locks Functioning Properly
- Check For Hydraulic Leaks
- Oil Level
- Lubrication of Critical Components
- Check For Overhead Obstructions
- Lift Arms Level, Arm Restraints Properly Adjusted
- All Screws, Bolts, and Pins Secured
- Surrounding Area Clean
- Operation, Maintenance and Safety Manuals on Site.

STEP 15

(Lubrication)

1. After installation and start up has been completed, lubricate lift components as described below.

(See Fig. 15.1)

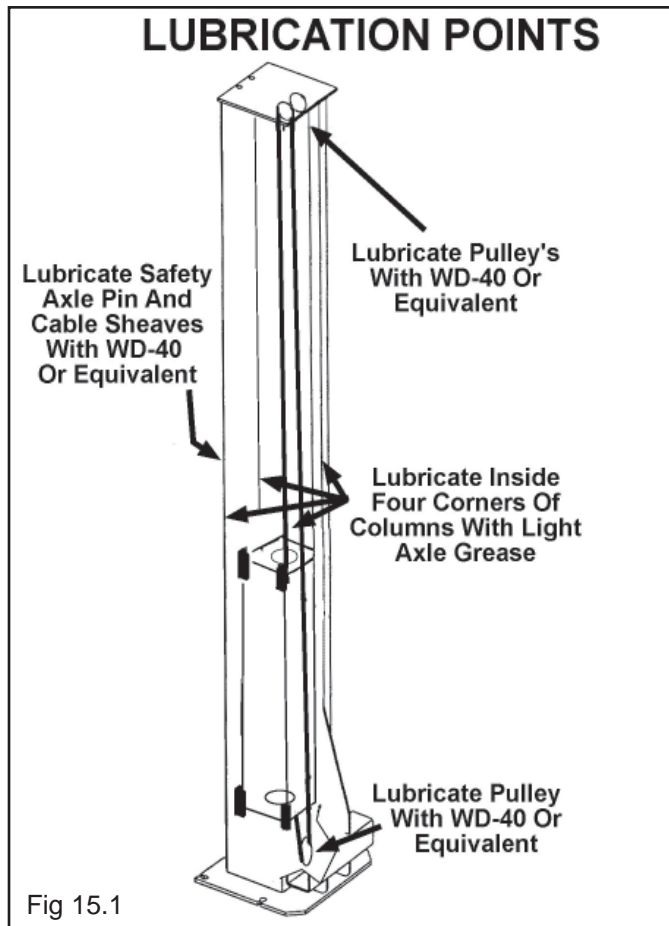

NOTE:

There will be initial stretching of the cables in the beginning and/or with increased loads. Adjust the cables as outlined above a week after first use, then every three to six months thereafter depending on usage and/or to compensate for stretch.

STEP 16

(Bleeding)

1. After electrical power is connected and oil reservoir is full press button to raise lift.



DANGER!

THE LIFT WILL MOVE DOWN WHEN BLEEDING MAKE SURE ALL EQUIPMENT, PERSONNEL, HANDS AND FEET ARE CLEAR BEFORE BLEEDING.

2. Continue raising until lift cylinders bottom out at full height. DO NOT continue pressing button after lift reaches full height. Damage to motor can occur if continued.

3. Lower the lift only HALF WAY by pressing the SAFETY RELEASE handle inward then pressing in the DOWN lever on power unit.

4. With the lift at half height, slowly loosen the BLEED SCREWS located at the top of each Cylinder to bleed trapped air. DO NOT completely remove bleed screws. Retighten after trapped air has escaped. (See Fig. 16.1)

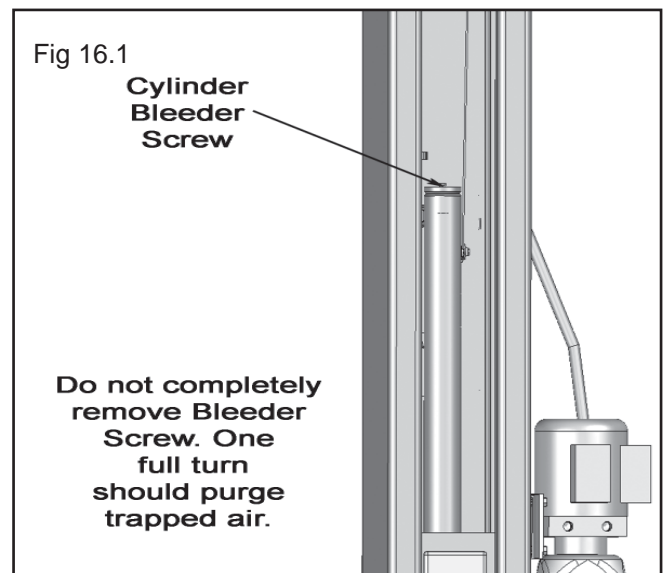

5. Lower the lift completely by pressing the SAFETY RELEASE Handle inward then pressing the DOWN lever on power Unit and repeat bleeding process one additional time.

OPTIONAL EQUIPMENT INSTALLATION

Utility Air-Electric Workstation

Utility Station may be mounted on the vertical column of the lift or on a wall.

IMPORTANT: Check State or Local codes for any height requirements for the electrical outlets before mounting.

To mount the Utility Station on a Lift Column, use the Box as a template, mark and drill 1 1/32" diameter holes. Use 5/16" diameter bolts and lock nuts to secure to the side of the lift.

IMPORTANT: The hole locations are critical to avoid interference with the carriage slide blocks.

For Wall mounting, mount in the same fashion, use appropriate hardware for either sheet rock or concrete.

IMPORTANT: All electrical wiring shall comply with all State and Local Codes.

Connect electrical wiring to single phase, 60Hz 115 volt electrical supply using suitable conduit (not supplied). The duplex receptacle must be connected through the GFCI with the input line to the box connected to a circuit breaker or time delay fuse rated at 20 amps. Both receptacles must be grounded to the box.

Connect main air supply to 1/4" ball valve inlet on the Utility Station (Run 1/2" line from compressor or main air system to Utility Station.)

Install Quick Couplers to the 1/4" male fittings on the box. The air supply between the filter and the lubricator will be non-lubricated, used for tire inflation or blowing off. The air outlet on the left side will be lubricated for air tool use.

Regulator Instructions

- Regulate pressure by raising the knob, then turning clockwise to increase and counterclockwise to decrease. Push knob down to lock setting.
- Adjust the oil mist using the screwdriver slot located on top of the lubricator.
- To fill the lubricator, first depressurize the air system, remove the slotted screw plug in the body. Replace the screw before repressurizing.

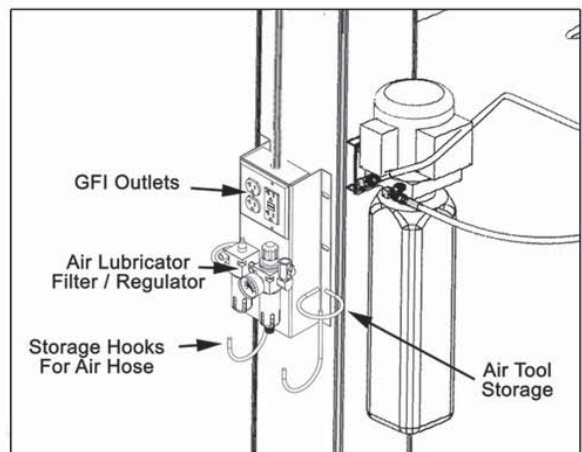
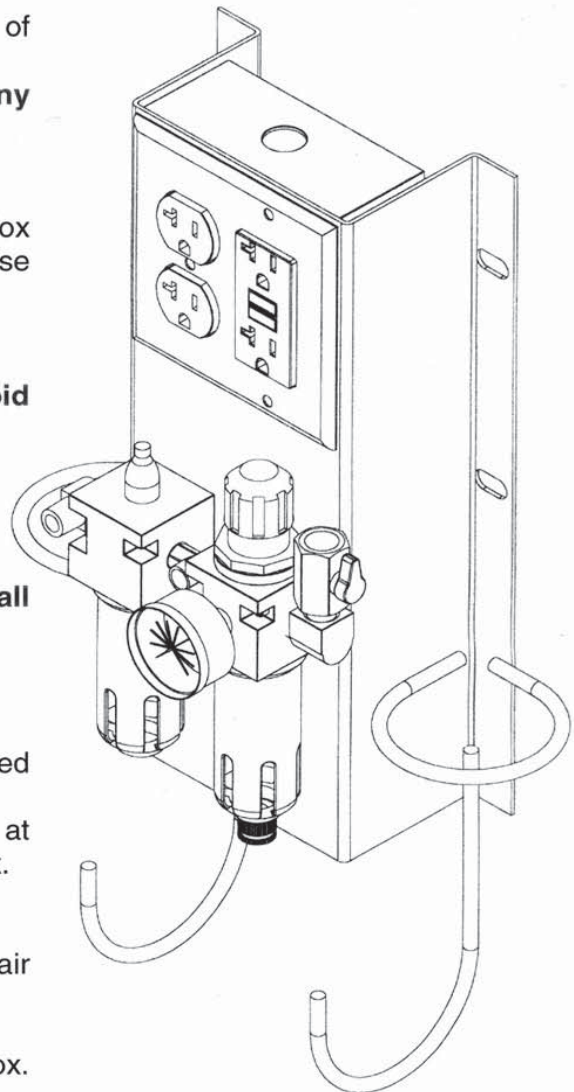

OPTIONAL FOOT GUARD INSTALLATION

1. Install the Foot Guards to the outside of the 4 Lift Arm Assemblies. Tighten the Hex Head Bolts. (See Fig 1-2)

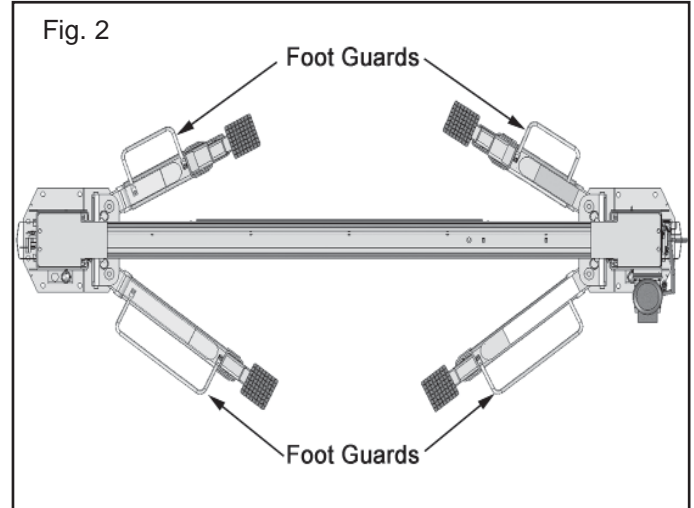
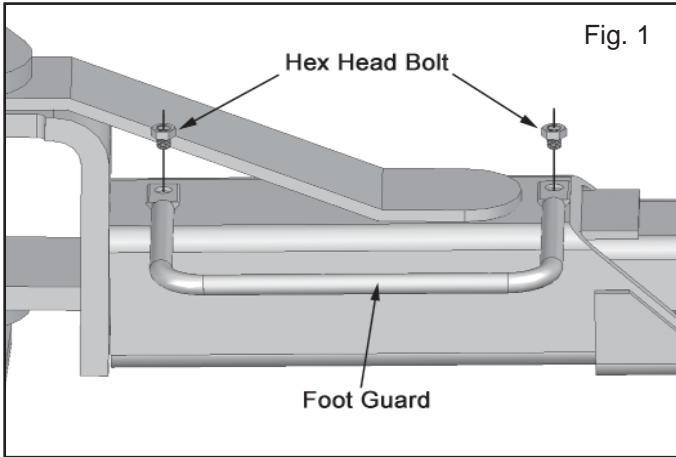

OPTIONAL CRADLE AND SCREW PAD ADAPTERS

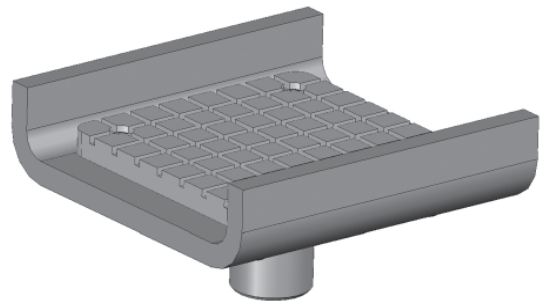
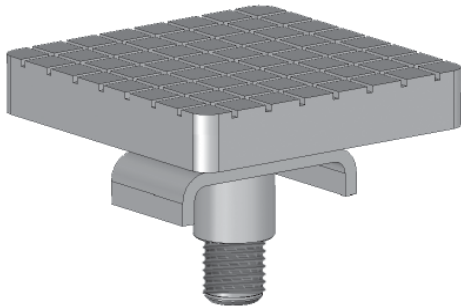

Optional Equipment available through your Authorized BendPak Dealer.

STEP 17

(Operation Instructions)

OWNER/EMPLOYER RESPONSIBILITIES

The Owner/Employer:

- Shall ensure that lift operators are qualified and that they are trained in the safe use and operation of the lift using the manufacturer's operating instructions; ALI/SM01-1, ALI Lifting it Right safety manual; ALI/ST-90 ALI Safety Tips card; ANSI/ALI ALOIM-2000, American National Standard for Automotive Lifts-Safety Requirements for Operation, Inspection and Maintenance; ALI/WL Series, ALI Uniform Warning Label Decals/Placards; and in the case of frame engaging lifts, ALI/LP-GUIDE, Vehicle Lifting Points/Quick Reference Guide for Frame Engaging Lifts.
- Shall establish procedures to periodically inspect the lift in accordance with the lift manufacturer's instructions or ANSI/ALI ALOIM-2000, American National Standard for Automotive Lifts-Safety Requirements for Operation, Inspection and Maintenance; and The Employer Shall ensure that lift inspectors are qualified and that they are adequately trained in the inspection of the lift.
- Shall establish procedures to periodically maintain the lift in accordance with the lift manufacturer's instructions or ANSI/ALI ALOIM-2000, American National Standard for Automotive Lifts-Safety Requirements for Operation, Inspection and Maintenance; and The Employer Shall ensure that lift maintenance personnel are qualified and that they are adequately trained in the maintenance of the lift.

- Shall maintain the periodic inspection and maintenance records recommended by the manufacturer or ANSI/ALI ALOIM-2000, American National Standard for Automotive Lifts-Safety Requirements for Operation, Inspection and Maintenance.

- Shall display the lift manufacturer's operating instructions; ALI/SM 93-1, ALI Lifting it Right safety manual; ALI/ST-90 ALI Safety Tips card; ANSI/ALI ALOIM-2000, American National Standard for Automotive Lifts-Safety Requirements for Operation, Inspection and Maintenance; and in the case of frame engaging lifts, ALI/LP-GUIDE, Vehicle Lifting Points/Quick Reference Guide for Frame Engaging Lifts; in a conspicuous location in the lift area convenient to the operator.

- Shall provide necessary lockout/tagout means for energy sources per ANSI Z244.1-1982 (R1993), Safety Requirements for the Lockout/Tagout of Energy Sources, before beginning any lift repairs.

- Shall not modify the lift in any manner without the prior written consent of the manufacturer.



LIFT OPERATION SAFETY

- **DAILY** inspect your lift. Never operate if it malfunctions or if it has broken or damaged parts. Use only qualified lift service personnel and genuine BendPak parts to make repairs.
- **THOROUGHLY** train all employees in use and care of lift, using manufacturer's instructions and "Lifting It Right" and "Safety Tips" supplied with the lift.
- **NEVER** allow unauthorized or untrained persons to position vehicle or operate lift.
- **PROHIBIT** unauthorized persons from being in shop area while lift is in use.
- **DO NOT** permit anyone on lift or inside vehicle when it is either being raised or lowered.
- **ALWAYS** keep area around lift free of tools, debris, grease and oil.
- **NEVER** overload lift. Capacity of lift is shown on nameplate affixed to the lift.
- **DO NOT** stand in front of the vehicle while it is being positioned in lift bay.
- **DO NOT** hit or run over lift arms or adapters. This could damage lift or vehicle. Before driving vehicle into lift bay, position arms and adapters to provide unobstructed entrance onto lift.
- **ALWAYS** load vehicle on lift carefully. Position the lift adapters to contact at the vehicle manufacturer's recommended lift points. Raise lift until adapters contact vehicle. Check adapters for secure contact with vehicle. Raise lift to desired working height. (See Fig.17.1)

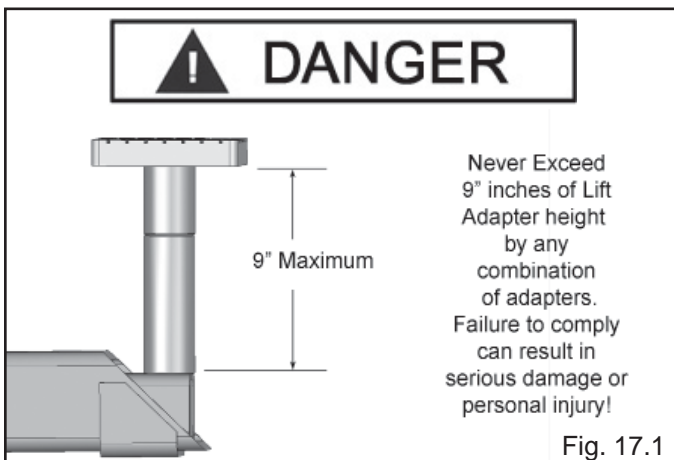

- **DO NOT** block open or override self-closing lift controls; they are designed to return to the "Off" or Neutral position when released.
- **DO NOT** remove or disable arm restraints.

- **ALWAYS** remain clear of lift when raising or lowering vehicles.
- **ALWAYS** use safety stands when removing or installing heavy components.
- **DO NOT** go under raised vehicle if safety locks are not engaged.



DANGER! VISUALLY CONFIRM THAT ALL PRIMARY SAFETY LOCKS ARE ENGAGED BEFORE ENTERING WORK AREA.

Suspension components on this lift are intended to raise and lower lift only and are not meant to be load holding devices. Remain clear of elevated lift unless visual confirmation is made that all primary safety locks are fully engaged and the lift is LOWERED onto the safety locks, Refer to installation /operation manual for proper safety lock procedures and /or further instruction.

- **NEVER LEAVE LIFT IN ELEVATED CONDITION** unless all Safety Locks are engaged.
- **AVOID** excessive rocking of vehicle while on lift.
- **ALWAYS CLEAR AREA** if vehicle is in danger of falling.



When lowering the lift **PAY CAREFUL ATTENTION** that all personnel and objects are kept clear. **ALWAYS** keep a visual line of site on the lift **AT ALL TIMES**. **ALWAYS** make sure that **ALL LOCKS** are disengaged. If one of the locks inadvertently locks on descent the lift and/or vehicle may disrupt causing personal injury or death,

- **ALWAYS REMOVE** tool trays, stands, etc. before lowering lift.
- **ALWAYS RELEASE** safety locks before attempting to lower lift.
- **ALWAYS POSITION** the lift arms and adapters to provide an unobstructed exit before removing vehicle from lift area.

TO RAISE THE LIFT



WARNING!

To avoid personal injury and/or property damage, permit only trained personnel to operate lift. After reviewing these instructions, get familiar with lift controls by running the lift through a few cycles before loading vehicle on lift. Always lift the vehicle using all four adapters. **NEVER** raise just one end, one corner, or one side of vehicle.

1. Before Loading: Lift must be fully lowered and service bay clear of all personnel before the vehicle is brought on lift with the swing arms set to the full drive-thru position.
2. Loading: Swing arms under vehicle and position adapters at vehicle manufacturer's recommended lift points. Use height extenders or optional frame-cradle adapters when necessary to ensure good contact. (See Fig 17.2-3)

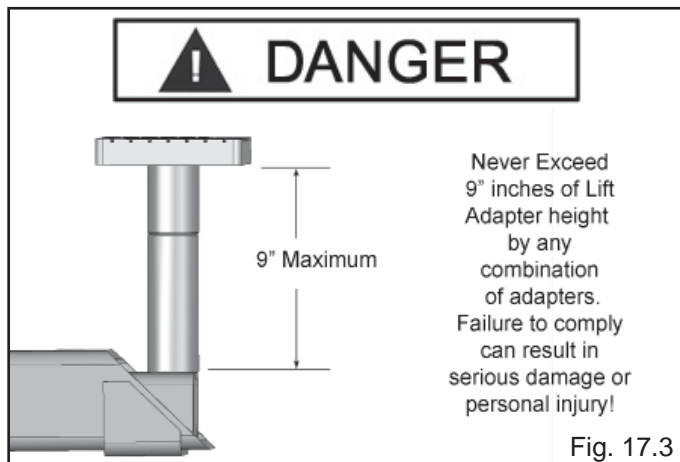
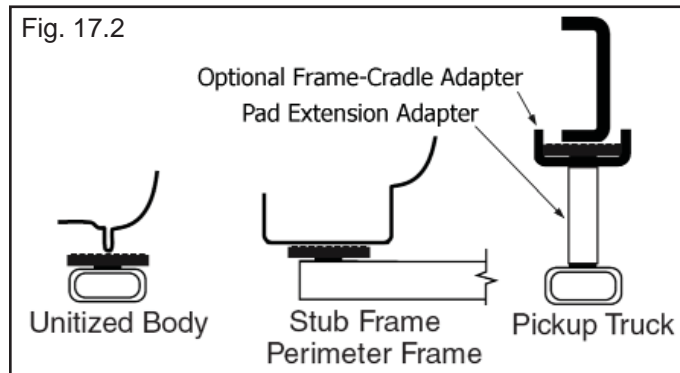

3. Some vehicles may have the manufacturer's Service Garage Lift Point locations identified by triangle shape marks on the undercarriage (reference ANSI/SAE J2184-1992). Also, there may be a label located on the right front door jamb area showing specific vehicle lift points.



WARNING!

Many specialty or modified vehicles cannot be raised on a two-post frame engaging lift. Contact vehicle manufacturer for raising or jacking details.

TYPICAL LIFTING POINTS

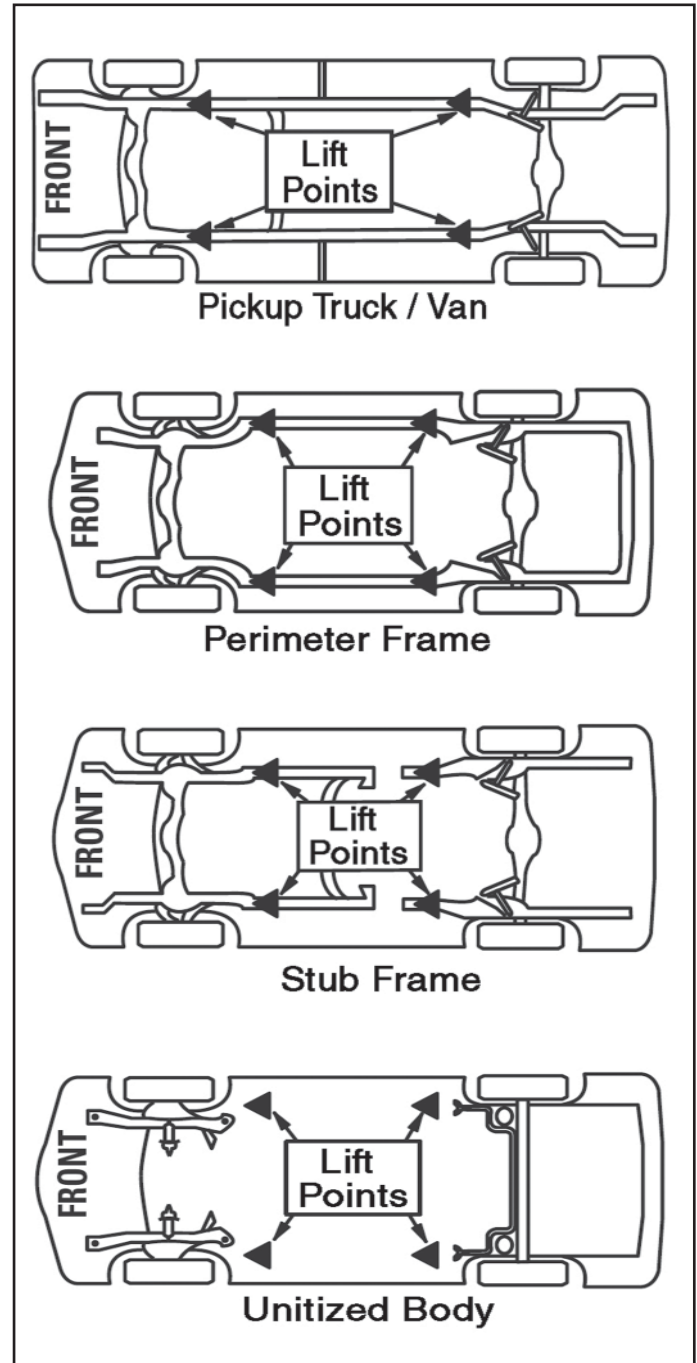

4. Position vehicle for proper weight distribution arms under vehicle to allow adapters to contact at the manufacturer's recommended pick up points.

5. If the specific vehicle lift points are not identified, or if the vehicle has additional or uniquely positioned payload, have a qualified person calculate the vehicle center of gravity or have the vehicle center of gravity determined at a vehicle scale. Load the vehicle with the center of gravity midway between adapters.

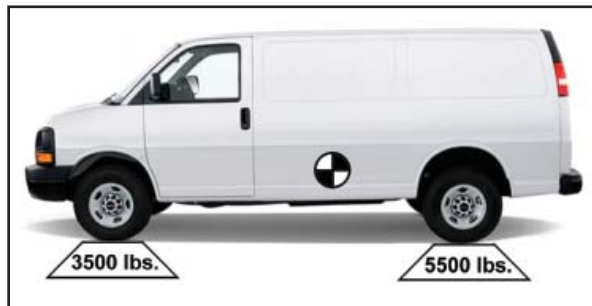

WARNING

Make sure vehicle is neither front nor rear heavy and select the proper configuration for the vehicle to be lifted (symmetric/asymmetric) as shown below. Center of balance should be midway between adapters.

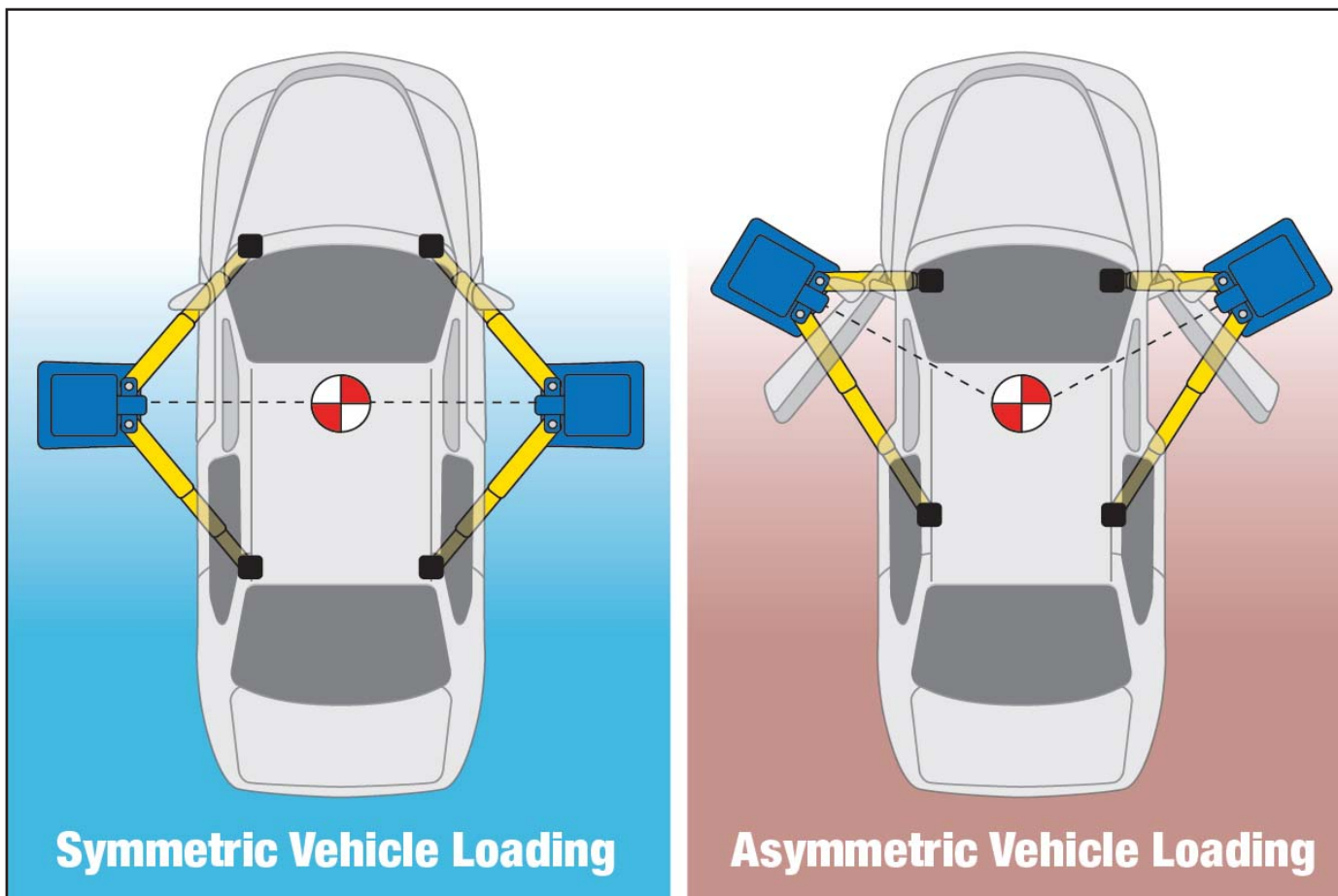

6. Push the **RAISE** button or rotate the control switch on the power unit.

Important Note:

**Allow (2) seconds between motor starts.
Failure to comply may cause motor burnout.**

7. Stop before making contact with vehicle. Check arm restraint pins for engagement. If required, slightly move arm to allow restraint gear and pawl to mesh. **DO NOT** hammer arm restraint pin down as this will damage the restraint gear teeth.

8. Raise vehicle until tires clear the floor.

9. Stop and check adapters for secure contact at vehicle manufacturer's recommended lift points.

10. Continue to raise to desired height only if vehicle is secure on lift.

11. **DO NOT** go near or under a raised vehicle if all four adapters are not in secure contact with vehicle at vehicle manufacturer's recommended lift points.

12. Repeat entire loading and raising procedures if required.

13. Lower lift onto safety locks.



DANGER!
VISUALLY CONFIRM THAT ALL PRIMARY SAFETY LOCKS ARE ENGAGED BEFORE ENTERING WORK AREA.
Suspension components on this lift are intended to raise and lower lift only and are not meant to be load holding devices. Remain clear of elevated lift unless visual confirmation is made that all primary safety locks are fully engaged and the lift is **LOWERED** onto the safety locks, Refer to installation /operation manual for proper safety lock procedures and /or further instruction.

- **DO NOT** enter work area or go under vehicle if safety locks are not engaged.
- **CLEAR AREA** if vehicle is in danger of falling.
- **DO NOT** position yourself between a wall and the lift. If the vehicle falls in that direction, you may be severely injured.

• Before attempting to lift pickup trucks or other truck frame vehicles, be sure that:

- ◆ Vehicle frame is strong enough to support its weight and has not been weakened by modification or corrosion.
- ◆ Vehicle individual axle weight does not exceed one-half lift capacity.
- ◆ Adapters are in secure contact with frame at vehicle manufacturers recommended lift points.
- ◆ Vehicle is stable on lift and neither front nor "tail" heavy.
- ◆ The overhead switch bar will contact the highest point on the vehicle.

WHILE USING LIFT

- Avoid excessive rocking of vehicle while on lift.
- Always use safety stands as needed or when removing or installing heavy components.

TO LOWER THE LIFT



WARNING!
When lowering the lift **PAY CAREFUL ATTENTION** that all personnel and objects are kept clear. **ALWAYS** keep a visual line of site on the lift **AT ALL TIMES. ALWAYS** make sure that **ALL LOCKS** are disengaged. If one of the locks inadvertently locks on descent the lift and/or vehicle may disrupt causing personal injury or death.

1. Remove all tools or other objects from the lift area.
2. Raise lift off safety locks. Make sure you raise the lift by at least two inches to allow adequate clearance for the locks to clear.
3. Push safety lock release handle fully and hold.
4. Push LOWERING valve handle to lower. Note: Both SAFETY LOCK release and LOWERING valve handles must be held down simultaneously to lower lift. Do not override self-closing lift controls.
5. Remain clear of lift when lowering vehicle. Observe pinch point warning decals.
6. Remove adapters from under vehicle and swing arms to full drive-thru position before moving vehicle.
7. If lift is not operating properly, Do Not use until adjustment or repairs are made by qualified lift service personnel.

MAINTENANCE INSTRUCTIONS



CAUTION!

If you are not completely familiar with automotive lift maintenance procedures; **STOP**: Contact factory for instructions. To avoid personal injury, permit only qualified personnel to perform maintenance on this equipment.

- Always keep bolts tight. Check periodically.
 - Always keep lift components clean.
 - Always if oil leakage is observed, call local service representative.
 - Always if electrical problems develop, call local service representative.
 - Always replace ALL FAULTY PARTS before lift is put back into operation.
 - Daily: Make a visual inspection of ALL MOVING PARTS and check for excessive signs of wear.
 - Daily: Check Safety Locks to insure they are in good operating condition.
 - Daily: Check cables and sheaves for wear. Replace worn parts as required with genuine BendPak parts.
 - Daily: Inspect adapters for damage or excessive wear. Replace as required with genuine BendPak parts.
 - Weekly: Lubricate all rollers with general purpose oil or WD-40.
 - Weekly: Check all cable connections, bolts and pins to insure proper mounting.
 - Monthly: Check equalizer cable tension. Adjust per lift installation instructions.
 - Monthly: Lubricate locking latch shafts. Push latch handle several times for oil to penetrate pivot points.
 - Every 3 Months: Check anchor bolts for tightness. Anchors should be torqued to 90 ft/lbs.
 - Semi-Annually: Check fluid level of lift power unit and refill if required per lift installation instructions.
- Replace all caution, warning or safety related decals on the lift if unable to read or missing. Reorder labels from BendPak.
 - Refer to ANSI/ALI ALOIM booklet for periodic inspection checklist and maintenance log sheet.

TO RAISE LIFT

- ◆ Read operating and Safety manuals before using lift.
- ◆ Always lift a vehicle according to the manufactures recommended lifting points.
- ◆ Position vehicle between columns.
- ◆ Adjust swing arms so that the vehicle is positioned with the center of gravity midway between pads.
- ◆ Use truck adapters as needed. Never exceed 9" of combined Pad height.
- ◆ **NEVER** use lift pad assemblies without rubber slip over pads in place.
- ◆ Raise the vehicle by depressing button until the vehicle just lifts off the ground. Recheck to make sure the vehicle is secure and all locking pins are lock in place.
- ◆ Raise vehicle to desired height. Lower vehicle onto nearest safety,
- ◆ Always ensure safeties are engaged before any attempt is made to work on or near vehicle.

TO LOWER THE LIFT

- ◆ First raise the lift clear to the safeties.
- ◆ Release safeties by pulling on the safety handle.
- ◆ Be sure tool trays, stands or personnel are cleared from under the vehicle.
- ◆ Lower vehicle by activating lowering handle on power unit.
- ◆ Before removing vehicle from lift; positron lift arms and supports to provide an unobstructed exit.
- ◆ **NEVER**, drive over lift arms.

REQUIRED MONTHLY MAINTENANCE

- ◆ Check all arm adjusting locks for proper operation.
- ◆ Check all cables connections, bolts and pins to insure proper mounting and torque.
- ◆ Visually inspect safeties for proper operation.
- ◆ Lubricate columns with grease.
- ◆ Inspect all anchors bolts and retighten if necessary.
- ◆ Check all columns for squareness and plumb.
- ◆ Inspect all pivot arms pins making sure they are properly secure.
- ◆ Check equalizer cable tension, and adjust if necessary.
- ◆ If lift is equipped with over head cut-off switch, check for proper operation.



1. **WARNING:** If cement anchor bolts are loose or any component of the lift is found to be defective, **DO NOT USE THE LIFT!!**
- 2, Never operate the lift with any person or equipment below the vehicle.
3. Never exceed the rated lift capacity.
4. Always insure the safeties are engaged before any attempt is made to work on or near the vehicle.
5. Never leave lift in elevated position unless the safeties are engaged.
6. Do not permit electric motor to get wet! Motor damage caused by dampness is not covered under warranty.



NEVER LIFT ANY VEHICLE IN ANY MANNER WITH LESS THE ALL FOUR (4) ARMS. RATED CAPACITY OF EACH LIFT ARM IS NO GREATER THAT ONE FOURTH (1/4) OF THE OVERALL LIFT CAPACITY.

Safe Lift Operation

Automotive and truck lifts are critical to the operation and profitability of your business. The safe use of this and other lifts in your shop is critical in preventing employee injuries and damage to customer's vehicles. By operating lifts safely you can insure that your shop is profitable, productive and safe.

Safe operation of automotive lifts requires that only trained employees should be allowed to use the lift.

TRAINING SHOULD INCLUDE, BUT NOT LIMITED TO:

- ◆ Proper positioning of the vehicle on the runway. (See manufacturers minimize wheel base loading requirements.)
- ◆ Use of the operating controls.
- ◆ Understanding the lift capacity.
- ◆ Proper use of jack stands or other load supporting devices.
- ◆ Proper use, understanding and visual identification of safety lock devices and their operation.
- ◆ Reviewing the safety rules.
- ◆ Proper housekeeping procedures (lift area should be free of grease, oil, tools, equipment, trash, and other debris).
- ◆ A daily inspection of the lift should be completed prior to its use. Safety devices, operating controls, lift arms and other critical parts should be inspected prior to using the lift.
- ◆ All maintenance and repairs of the lift should be completed by following the manufacturer's requirements. Lift repair parts should meet or exceed OEM specifications. Repairs should only be completed by a qualified lift technician.
- ◆ The vehicle manufacturer's recommendations should be used for spotting and lifting the vehicle.

LIFT OPERATION SAFETY

- ◆ It is important that you know the load limit. Be careful that you do not overload the lift . If you are unsure what the load limit is, check the data plate found on one of the lift columns or contact the manufacturer.
- ◆ The center of gravity should be followed closely to what the manufacturer recommends.
- ◆ Always make sure you have proper overhead clearance. Additionally, check that attachments, (vehicle signs, campers antennas, etc.) are not in the way.
- ◆ Be sure that prior to the vehicle being raised, the doors, trunk, and hood are closed securely.
- ◆ Prior to being raised, make sure there is no one standing closer than six feet from the lift.
- ◆ After positioning the vehicle on the lift runways, set the emergency brake, make sure the ignition is off, the doors are closed, overhead obstructions are cleared, and the transmission is in neutral.
- ◆ Double check that the automatic chock devices are in position and then when the lift is raised, observe the chocks.
- ◆ Put pads or adapters in the right position under the contact points that have been recommended.
- ◆ The lift should be raised just until the vehicle's wheels are about one foot off the ground. If contact with the vehicle is uneven or it appears that the vehicle is not sitting secure, carefully lower the lift and readjust.
- ◆ Always consider potential problems that might cause a vehicle to slip, i.e., heavy cargo, undercoating, etc.
- ◆ Pay attention when walking under a vehicle that is up on the hydraulic lift.



- ◆ **DO NOT** leave the controls while the lift is still in motion.
- ◆ **DO NOT** stand directly in front of the vehicle or in the bay when vehicle is being loaded or driven into position.
- ◆ **DO NOT** go near vehicle or attempt to work on the vehicle when being raised or lowered.
- ◆ **REMAIN CLEAR** of lift when raising or lowering vehicle.
- ◆ **DO NOT** rock the vehicle while on the lift or remove any heavy component from vehicle that may cause excessive weight shift.
- ◆ **DO NOT** lower the vehicle until people, materials, and tools are clear.
- ◆ **ALWAYS INSURE** that the safeties are engaged and lowered on to the safety ladders before any attempt is made to work on or near vehicle.
- ◆ Some vehicle maintenance and repair activities may cause the vehicle to shift. Follow the manufacturer's guidelines when performing these operations. The use of jack stands or alternate lift points may be required when completing some repairs.
- ◆ **READ AND UNDERSTAND** all safety warning procedures before operating lift.
- ◆ **KEEP HANDS AND FEET CLEAR.** Remove hands and feet from any moving parts. Keep feet clear of lift when lowering. Avoid pinch points.
- ◆ **ONLY TRAINED OPERATORS** should operate this lift. All non-trained personnel should be kept away from work area. Never let non-trained personnel come in contact with, or operate lift.
- ◆ **USE LIFT CORRECTLY.** Use lift in the proper manner. Never use lifting adapters other than what is approved by the manufacturer.
- ◆ **DO NOT** override self-closing lift controls.
- ◆ **CLEAR AREA** if vehicle is on danger of falling.
- ◆ **STAY ALERT.** Watch what you are doing. Use common sense. Be aware.
- ◆ **CHECK FOR DAMAGED PARTS.** Check for alignment of moving parts, breakage of parts or any condition that may affect its operation. Do not use lift if any component is broken or damaged.
- ◆ **NEVER** remove safety related components from the lift. Do not use lift if safety related components are damaged or missing.
- ◆ When the lift is being lowered, make sure everyone is standing at least six feet away.
- ◆ Be sure there are no jacks, tools, equipment, left under the lift before lowering.
- ◆ Always lower the vehicle down slowly and smoothly.

⚠ WARNING

WIRE ROPE INSPECTION AND MAINTENANCE

- Lifting cables should be replaced every three years or when visible signs of damage are apparent. **DO NOT USE LIFT WITH DEFECTIVE: WORN CABLES.**
- Wire rope should be maintained in a well-lubricated condition at all times. Wire rope is only fully protected when each wire strand is lubricated both internally and externally. Excessive wear will shorten the life of the wire rope. The factory suggested wire rope lubricant that penetrates to the core of the rope and provides long term lubrication between each individual strand is AMSOIL Synthetic Open Gear and Wire Rope Compound or 90WT gear oil or similar heavy lubricant. In order to make sure that the inner layers of the rope remains well lubricated, lubrication should be carried out at intervals not exceeding three months during operation.
- All sheaves and guide rollers in contact with the moving rope should be given regular visual checks for surface wear and lubricated to make sure that they run freely. This operation should be carried out at appropriate intervals generally not exceeding three months during operation. For all sheave axles, the factory recommends standard wheel bearing grease. For all sheaves and /or guide rollers, the factory recommends 90 WT gear oil or similar heavy lubricant applied by any method including pump / spray dispensing, brush, hand and /or swabbing.

Failure to read, understand, and follow these instructions may cause death or serious injury.
Read and understand these instructions before using lift.

SAFETY INSTRUCTIONS

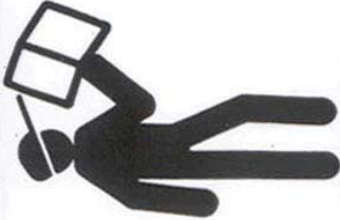

Read operating and safety manuals before using lift.

©

SAFETY INSTRUCTIONS



Proper maintenance and inspection is necessary for safe operation.

©

SAFETY INSTRUCTIONS

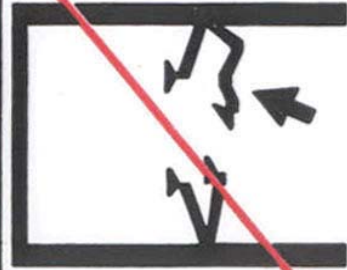

Do not operate a damaged lift.

©

The messages and pictographs shown are generic in nature and are meant to generally represent hazards common to all automotive lifts regardless of specific style

Funding for the development and validation of these labels was provided by the Automotive Lift Institute, PO Box 33116 Indialantic, FL 32903

They are protected by copyright. Set of labels may be obtained from ALI or its member companies

© 1992 by ALI, Inc

ALI/WL101e



WARNING

WIRE ROPE INSPECTION AND MAINTENANCE

- ◆ Lifting cables should be replaced every three - five years or when visible signs of damage are apparent. DO NOT USE LIFT WITH DEFECTIVE / WORN CABLES.
- ◆ Lifting cables should be maintained in a well-lubricated condition at all times. Wire rope is only fully protected when each wire strand is lubricated both internal and external. Excessive wear will shorten the life of the wire rope. The factory suggested wire rope lubricant that penetrates to the core of the rope and provides long-term lubrication between each individual strand is 90-WT gear oil or ALMASOL® Wire Rope Lubricant. In order to make sure that the inner layers of the rope remain well lubricated, lubrication should be carried out at intervals not exceeding three months during operation.
- ◆ All sheaves and guide rollers in contact with the moving rope should be given regular visual checks for surface wear and lubricated to make sure that they run freely. This operation should be carried out at appropriate intervals generally not exceeding three months during operation. For all sheave axles, the factory recommends standard wheel bearing grease. For all sheaves and/or guide rollers, the factory recommends 90-WT gear oil or similar heavy lubricant applied by any method including pump / spray dispensing, brush, hand and/or swabbing.

HOW OFTEN TO INSPECT

- ◆ Lifting cables should be visually inspected at least once each day when in use, as suggested by American Petroleum Institute (API) RP54 guidelines.
- ◆ Any lifting cables that have met the criteria for removal must be immediately replaced.

WHEN TO REPLACE LIFTING CABLES DUE TO BROKEN WIRES

- ◆ Lifting cables should be removed from service when you see six randomly distributed broken wires within any one lay length, or three broken wires in one strand within one lay length.

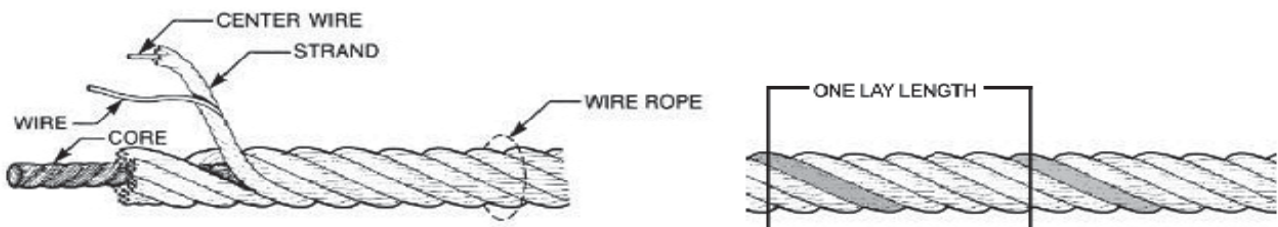

The three basic components of a typical wire rope.

OTHER REASONS TO REPLACE LIFTING CABLES

- ◆ Corrosion that pits the wires and/or connectors.
- ◆ Evidence of kinking, crushing, cutting, bird-caging or a popped core.
- ◆ Wear that exceeds 10% of a wire's original diameter.
- ◆ Evidence of heat damage.

HOW TO FIND BROKEN WIRES

- ◆ The first step is to relax your rope to a stationary position and move the pick-up points off the sheaves. Clean the surface of the rope with a cloth — a wire brush, if necessary — so you can see any breaks.
- ◆ Flex the rope to expose any broken wires hidden in the valleys between the strands.
- ◆ Visually check for any broken wires. One way to check for crown breaks is to run a cloth along the rope to check for possible snags.
- ◆ With an awl, probe between wires and strands and lift any wires that appear loose. Evidence of internal broken wires may require a more extensive rope examination.

⚠ CAUTION

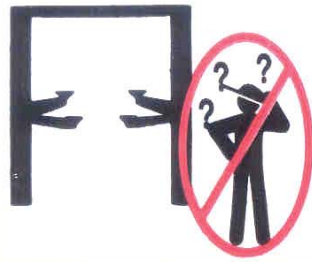

Lift to be used by trained operator only.

©

⚠ CAUTION



Authorized personnel only in lift area.

©

⚠ WARNING



Clear area if vehicle is in danger of falling.

©

⚠ WARNING



Position vehicle with center of gravity midway between adapters.

©

⚠ CAUTION

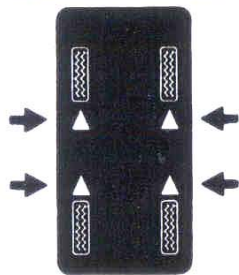

Use vehicle manufacturer's lift points.

©

⚠ CAUTION

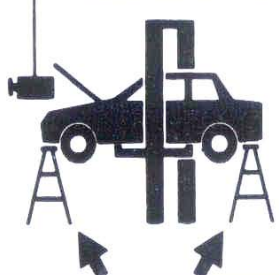

Always use safety stands when removing or installing heavy components.

©

⚠ WARNING



Remain clear of lift when raising or lowering vehicle.

©

⚠ WARNING



Avoid excessive rocking of vehicle while on lift.

©

⚠ CAUTION

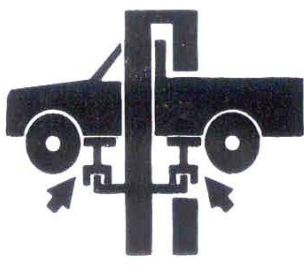

Use height extenders when necessary to ensure good contact.

©

⚠ CAUTION

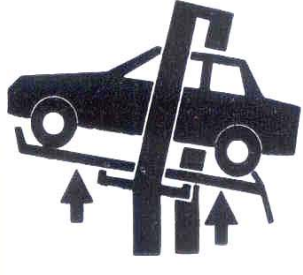

Auxiliary adapters may reduce load capacity.

©

⚠ WARNING



Do not override self-closing lift controls.

©

⚠ WARNING

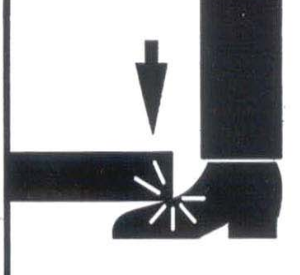

Keep feet clear of lift while lowering.

©

The messages and pictographs shown are generic in nature and are meant to generally represent hazards common to all automotive lifts regardless of specific style.

Funding for the development and validation of these labels was provided by the Automotive Lift Institute, PO Box 33116 Indialantic, FL. 32903.

They are protected by copyright. Set of labels may be obtained from ALI or its member companies.

© 1992 by ALI, Inc.

ALI/WL101c

The messages and pictographs shown are generic in nature and are meant to generally represent hazards common to all automotive lifts regardless of specific style.

Funding for the development and validation of these labels was provided by the Automotive Lift Institute, PO Box 33116 Indialantic, FL. 32903.

They are protected by copyright. Set of labels may be obtained from ALI or its member companies.

© 1992 by ALI, Inc.

ALI/WL101w

LIFT WILL NOT RAISE

POSSIBLE CAUSE

1. Air in oil, (1,2,8,13)
2. Cylinder binding, (9)
3. Cylinder leaks internally, (9)
4. Motor run backward under pressure, (11)
5. Lowering valve leaks, (3,4,6,10,11)
6. Motor runs backwards, (7,14,11)
7. Pump damaged, (10,11)
8. Pump won't prime, (1,8,13,14,3,12,10,11)
9. Relief valve leaks, (10,11)
10. Voltage to motor incorrect, (7,14,11)

REMEDY

1. Check for proper oil level
2. Bleed cylinders
3. Flush- Release valve to get rid of possible contamination.
4. Dirty oil
5. Tighten all fasteners
6. Check for free movement of release
7. Check motor is wired correctly.
8. Oil seal damaged or cocked
9. See Installation Manual
10. Replace with new part
11. Return unit for repair
12. Check pump-mounting bolts
13. Inlet screen clogged
14. Check wall outlet voltages and wiring

INSTRUCTION

The oil level should be up to the bleed screw in the reservoir with the lift all the way down.

See Installation Manual

Hold release handle down and start unit allowing it to run for 15 seconds.

Replace oil with clean Dexron ATF

Tighten fasteners to recommended torques.

If handle does not move freely, replace bracket or handle assembly.

Compare wiring of motor to electrical diagram on drawing.

Replace oil seal around pump shaft.

Consult Lift Manufacturer

Replace with new part

Return unit for repair

Bolts should be 15 to 18 ft. lbs.

Clean inlet screen or replace

Make sure unit and wall outlet are wired properly.

MOTOR WILL NOT RUN

POSSIBLE CAUSE

1. Fuse blown, (5,2,1,3,4)
2. Limit switch burned out, (1,2,3,4)
3. Microswitch burned out, (1,2,3,4)
4. Motor burned out, (1,2,3,4,6)
5. Voltage to motor incorrect, (2,1,8)

REMEDY

1. Check for correct voltage
2. Check motor is wired correctly
3. Don't use extension cords
4. Replace with new part
5. Reset circuit breaker/fuse
6. Return unit for repair
7. See Installation Manual
8. Check wall outlet voltage and wiring

INSTRUCTION

- Compare supply voltage with voltage on motor nametag. Check that the wire is sized correctly. N.E.C. table 310-12 requires AWG 10 for 25 Amps.
- Compare wiring of motor to electrical diagram on drawing.
- According to N.E.C. : " The size of the conductors...should be such that the voltage drop would not exceed 3% to the farthest outlet for power..." Do not run motor at 115 VAC – damage to the motor will occur.
- Replace with new part
- Reset circuit breaker/fuse
- Return unit for repair
- See Installation Manual
- Make sure unit and wall outlet is wired properly. Motor must run at 208/230 VAC.

LIFT LOWERS SLOWLY OR NOT AT ALL

POSSIBLE CAUSE

1. Cylinders binding, (1)
2. Release valve clogged, (5,4,2,3)
3. Pressure fitting too long, (6)

REMEDY

1. See Installation Manual
2. Replace with new part
3. Return for repair
4. Check oil
5. Clean release valve
6. Replace fitting with short thread lead

INSTRUCTION

- Consult Lift Manufacturer
- Replace with new part
- Return for repair
- Use clean 10-WT hydraulic oil or Dexron-III automatic transmission fluid only. If ATF is contaminated, replace with clean ATF and clean entire system.
- Wash release valve in solvent and blow out with air.
- Replace fitting with short thread lead

WILL NOT RAISE LOADED LIFT

POSSIBLE CAUSE

1. Air in oil, (1,2,3,4)
2. Cylinder binding, (5)
3. Cylinder leaks internally, (5)
4. Lift overloaded, (6,5)
5. Lowering valve leaks, (7,8,1,5,9)
6. Motor runs backwards, (10,12,9)
7. Pump damaged, (5,9)
8. Pump won't prime, (1,2,3,4,5,11,9)
9. Relief valve leaks, (8,5,9)
10. Voltage to motor incorrect, (10,12,5)

REMEDY

1. Check oil level
2. Check/Tighten inlet tubes
3. Oil seal damaged or cocked
4. Bleed cylinders
5. See Installation Manual
6. Check vehicle weight
7. Flush release valve
8. Replace with new part
9. Return unit for repair
10. Check motor is wired correctly
11. Inlet screen clogged
12. Check wall outlet voltage and wiring

INSTRUCTION

- The oil level should be up to the bleed screw in the reservoir with the lift all the way down.
- Replace inlet hose assembly.
- Replace oil seal and install
- See Installation Manual
- Consult Lift Manufacturer
- Compare weight of vehicle to weight limit of the lift.
- Hold release handle down and start unit allowing it to run for 15 seconds.
- Replace with new part
- Return unit for repair
- Compare wiring of motor to electrical diagram on unit drawing
- Clean inlet screen or replace.
- Make sure unit and wall outlet is wired properly.

LIFT WILL NOT STAY UP

POSSIBLE CAUSE

1. Air in oil, (1,2,3)
2. Check valve leaks, (6)
3. Cylinders leak internally, (7)
4. Lowering valve leaks, (4,5,1,7,6)
5. Leaking fittings, (8)

REMEDY

1. Check oil level
2. Oil seal damaged and cocked
3. Bleed cylinder
4. Flush release valve
5. Replace with new valve
6. Return unit for repair
7. See Installation Manual
8. Check complete hydraulic system for leaks

INSTRUCTION

The oil level should be up to the bleed screw in the reservoir with the lift all the way down.

Replaced oil seal around pump shaft.

Refer to Installation Manual

Hold release handle down and start unit allowing it to run for 15 seconds.

Replace with new valve

Return unit for repair

Consult Lift Manufacturer

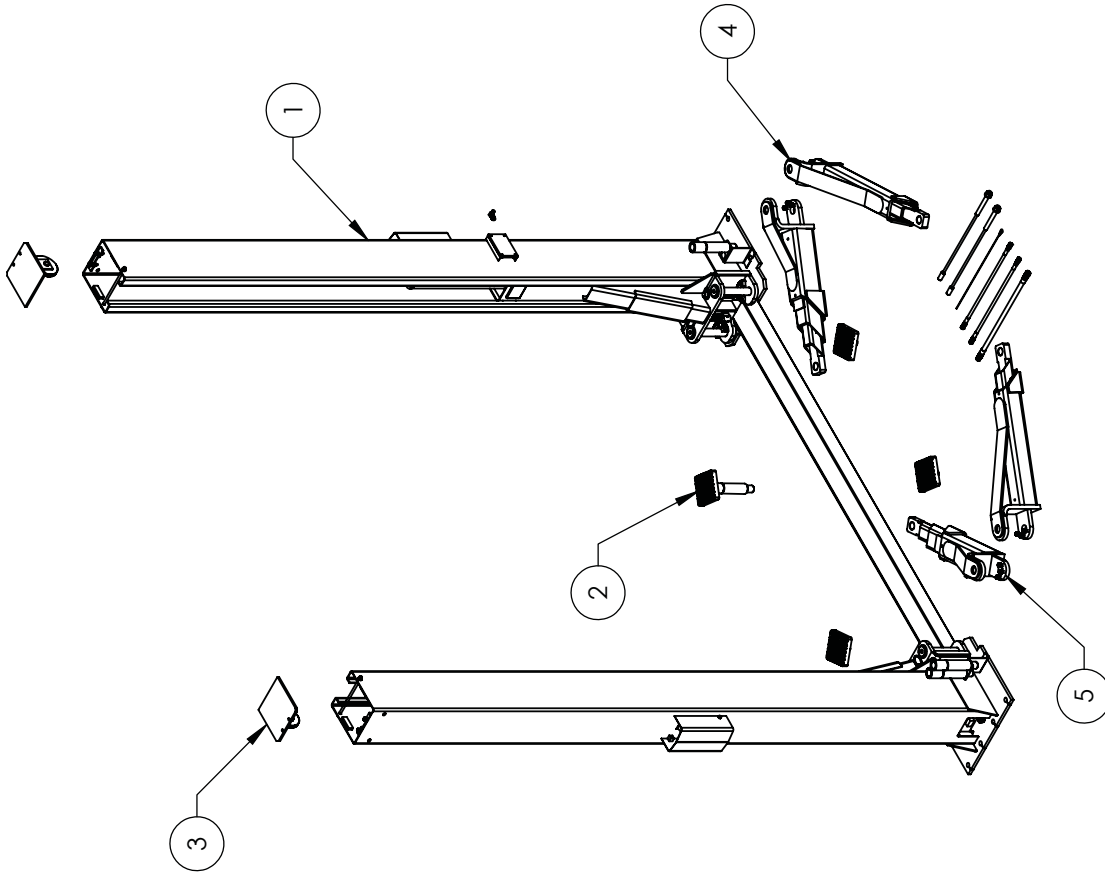

ITEM NO	PART NUMBER	DESCRIPTION	QTY	REV
1	5245131	XPR-9FD LIFT SUPERSTRUCTURE	1	B
2	5250122	XPR-9FD PARTS BOX	1	B
3	5215226	XP/XPR-9FD/FDX, XPR-9FS/FSX TOP EQUALIZER PULLEY PLATE ASSEMBLY	2	B
4	5215195	XPR-9/10C/CX LOW PROFILE MEDIUM ARM ASSEMBLY	2	A
5	5210170	XPR-9/FD/FS/10C/AC LOW PROFILE TRIPLE TELESCOPING ARM ASSEMBLY	2	A

DO NOT SCALE DRAWING

DIMENSIONS ARE IN MM

DRAWN: TM 02/10/2010
 CHECKED: AC 04/30/2010

NAME: _____ DATE: _____

THIRD ANGLE PROJECTION

TITLE: XPR-9FD RECEIVED LIFT

SIZE DWG. NO. 5260135
 REV B

MATERIAL: ---
 SIZE: ---

SCALE: 1:35 SHEET 1 OF 2

BendPak 1645 LEMONWOOD DR. SANTA PAULA, CA 93060

PROPRIETARY AND CONFIDENTIAL. THE INFORMATION CONTAINED IN THIS DRAWING IS THE SOLE PROPERTY OF BENDPAK INC. ANY REPRODUCTION OR TRANSMISSION OF THIS DRAWING WITHOUT THE WRITTEN PERMISSION OF BENDPAK INC. IS PROHIBITED.

NOTE: UNLESS OTHERWISE SPECIFIED, SEE SHIPPING INSTRUCTIONS FOR FINAL PACKAGING

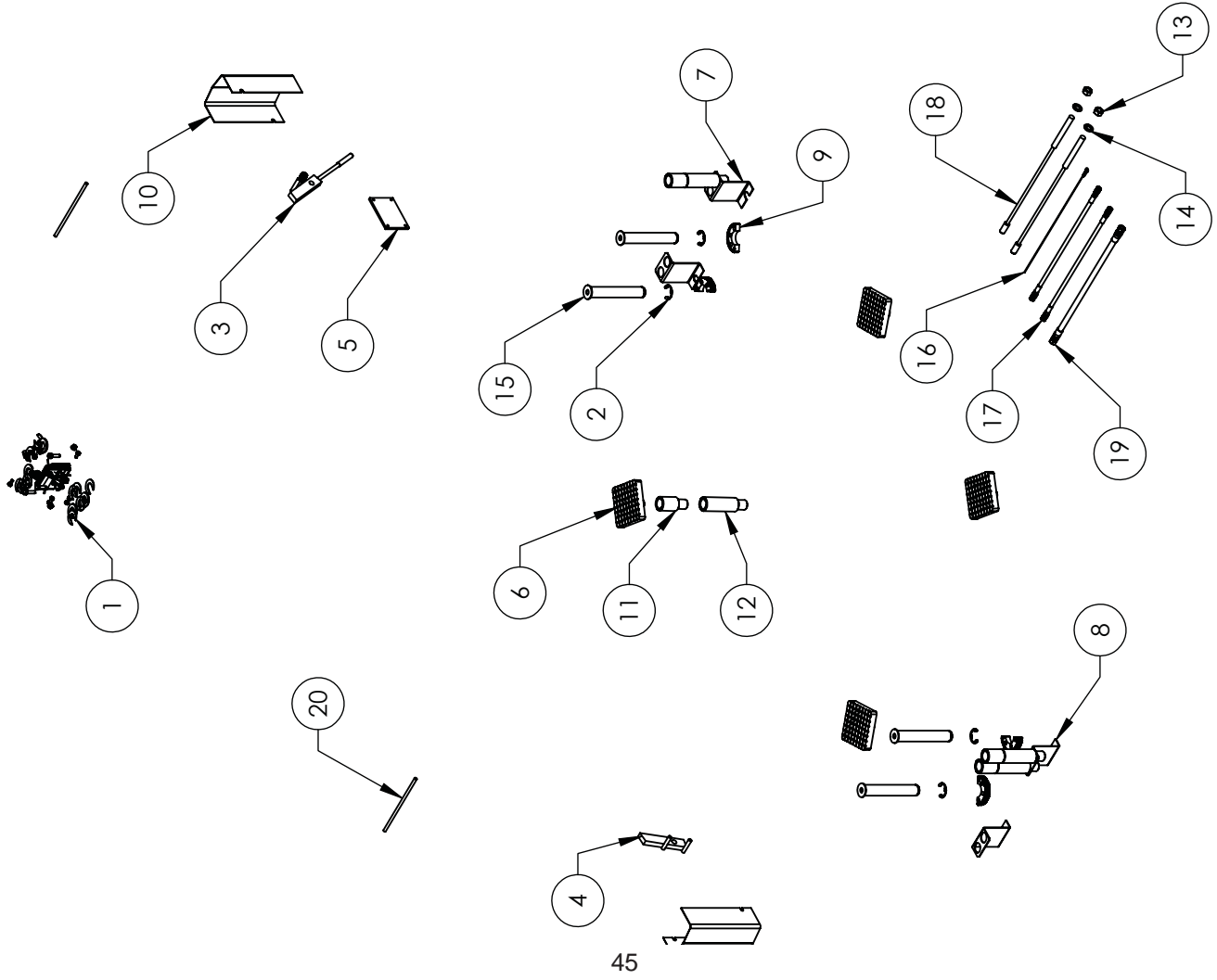

ITEM NO	PART NUMBER	DESCRIPTION	QTY	REV
1	5174114	XPR-9FD/FDX/12FD PARTS BAG	1	B
2	5540129	ERING Ø38mm OD	4	A
3	5210007	XP/XPR POWER SIDE SAFETY ASSEMBLY	1	A
4	5210010	XP/XPR OFF SIDE SAFETY WELDMENT	1	A
5	5715003	POWER UNIT VIBRATION DAMPENER	1	B
6	5215250	MD-6XP, ALL XP/XPR SLIP ON LIFT PAD ASSEMBLY	4	B
7	5730663	XP/XPR-9/10 POST ASSEMBLY LIFT HEAD FOOT GUARD R.H.	2	A
8	5730664	XP/XPR-9/10 POST ASSEMBLY LIFT HEAD FOOT GUARD L.H.	2	A
9	5736171	MX, XPR-9/10 BOLT ON ARM RESTRAINT GEAR	4	B
10	5210009	ALL XP, XPR-7/9FD/10/12/12FD/15/18C OFF SIDE SAFETY COVER	2	A
11	5746390	XP/XPR/RJ/MX/MD-6XP SHORT LIFT PAD EXTENSION (11.3mm L.G.)	4	A
12	5746395	MX/XP/XPR LONG LIFT PAD EXTENSION (182mm L.G.)	4	A
13	5535358	NUT M18 x 2.5NL	2	-
14	5545342	WASHER M18 FLAT	2	-
15	5505116	MX-10, XPR-9/10 LIFT HEAD PIN WELDMENT	4	A
16	5595501	XP/XPR-9FD Ø2.4mm x 721.4 SAFETY CABLE	1	A
17	5570119	XP/XPR-9FD HYDRAULIC HOSE ASSY Ø6.35 x 1384mm DS	2	A
18	5595029	XPR-9FD CABLE ASSY Ø10 x 10445mm	2	D
19	5570113	XP/XPR-9FD HYDRAULIC HOSE ASSY Ø10 x 2896mm DS	1	A
20	5746167	DOUBLE THREADED ROD M10 x 1.5 x 270	2	A

DO NOT SCALE DRAWING

DIMENSIONS ARE IN MM

MATERIAL: ----

NAME	DATE
TM	02/10/2010
AC	04/30/2010

DRAWN: TM
CHECKED: AC

THIRD ANGLE PROJECTION

PROPRIETARY AND CONFIDENTIAL

TITLE: XPR-9FD PARTS BOX

SIZE: DWG. NO. **A** 5050100

REV **R**

1645 LEMONWOOD DR. SANTA PAULA, CA 93060

**E: UNLESS OTHERWISE SPECIFIED,
INSERT PARTS BAG INTO PARTS BOX FOR SHIPMENT.**

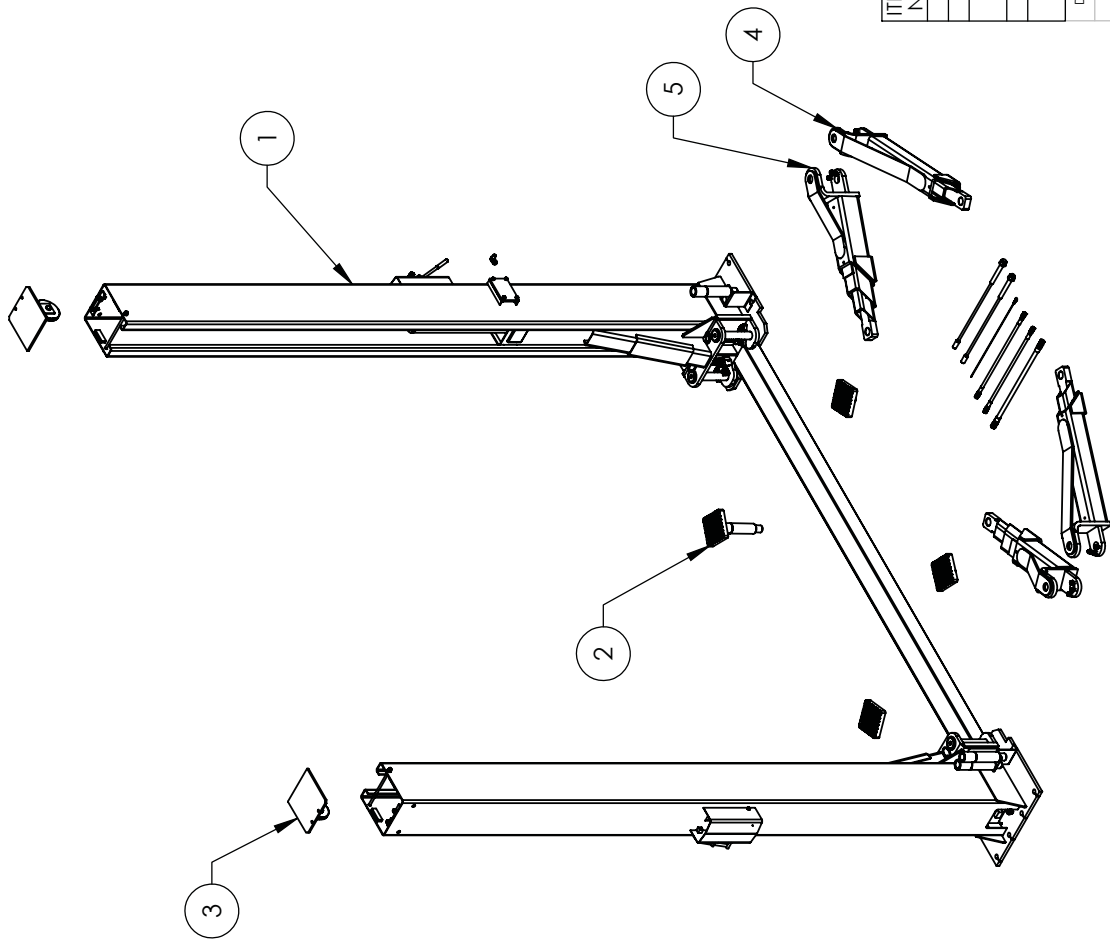

ITEM NO	PART NUMBER	DESCRIPTION	QTY	REV
1	5245132	XPR-9FDX LIFT SUPERSTRUCTURE	1	B
2	5250123	XPR-9FDX PARTS BOX	1	B
3	5215226	XP/XPR-9FD/FDX, XPR-9FS/FSX TOP EQUALIZER PULLEY	2	B
4	5215195	XPR-9/10C/CX LOW PROFILE MEDIUM ARM ASSEMBLY	2	A
5	5210170	XPR-9F/FD/FS/10C/AC LOW PROFILE TRIPLE TELESCOPING ARM ASSEMBLY	2	A

DO NOT SCALE DRAWING
DIMENSIONS ARE IN MM

NAME: TM DATE: 02/10/2010
DRAWN: AC CHECKED: AC 04/30/2010

THIRD ANGLE PROJECTION

TITLE: XPR-9FDX RECEIVED LIFT

SIZE: DWG. NO. A 5260136 REV B

SCALE: 1:35

1645 LEMONWOOD DR. SANTA PAULA, CA 93060

PROPRIETARY AND CONFIDENTIAL
THE INFORMATION CONTAINED IN THIS DRAWING IS THE PROPERTY OF BENDPAK, INC. NO REPRODUCTION OR TRANSMISSION OF ANY KIND WITHOUT THE WRITTEN PERMISSION OF BENDPAK, INC. IS PROHIBITED.

**NOTE: UNLESS OTHERWISE SPECIFIED,
1. SEE SHIPPING INSTRUCTIONS FOR FINAL PACKAGING**

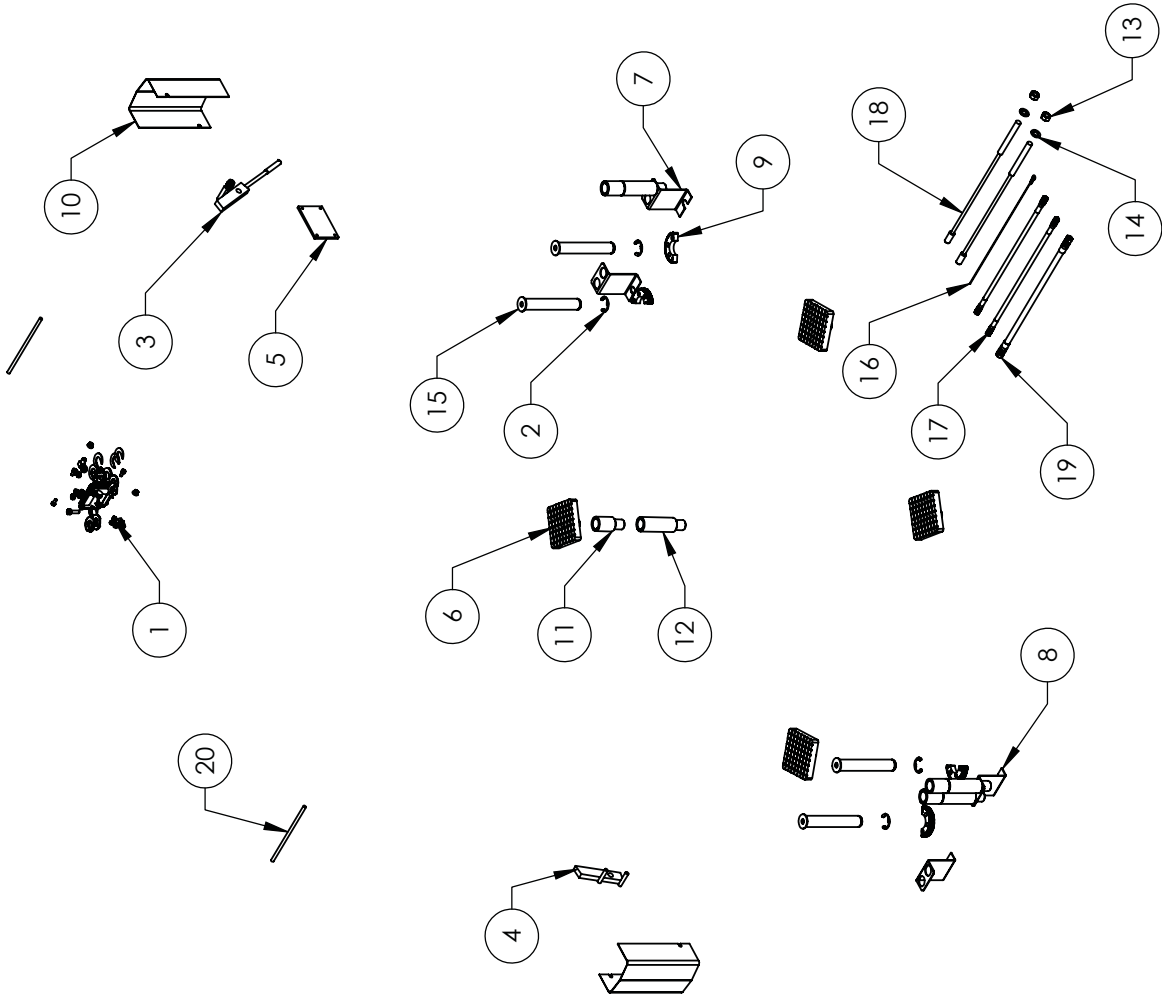

NOTE: UNLESS OTHERWISE SPECIFIED.

1. INSERT PARTS BAG INTO PARTS BOX FOR SHIPMENT
2. SEE SHIPPING INSTRUCTIONS FOR FINAL PACKAGING
3. THREAD 5535358 ONTO CABLES WITH 5545342 FOR SHIPMENT

NEXT ASSEMBLY
5260136

ITEM NO	PART NUMBER	DESCRIPTION	QTY	REV
1	5174114	XPR-9FDX/12FD PARTS BAG	1	B
2	5540129	ERING Ø38mm OD	4	A
3	5210007	XP/XPR POWER SIDE SAFETY ASSEMBLY	4	A
4	5210010	XP/XPR OFF SIDE SAFETY ASSEMBLY	4	A
5	5115003	POWER UNIT VIBRATION DAMPENER	4	B
6	5215230	MD-6XP ALL XPR SLIP ON LIFT PAD ASSEMBLY	4	B
7	5730663	XPR-7/RF, XP/XPR-9/10 POST ASSEMBLY LIFT HEAD FOOT GUARD R.H.	2	A
8	5730664	XPR-7/RF, XP/XPR-9/10 POST ASSEMBLY LIFT HEAD FOOT GUARD L.H.	2	A
9	5736171	MX_XPR-9/10 BOLLON ARM RESTRAINT GEAR	4	B
10	5210009	ALL XP, XPR-7/9FD/10/12/12FD/15/18C OFF SIDE SAFETY COVER	2	A
11	5746390	XP/XPR/RJ/MX/MD-6XP SHORT LIFT PAD EXTENSION (113mm LG.)	4	A
12	5746395	MX/XP/XPR LONG LIFT PAD EXTENSION (182mm LG.)	4	A
13	5535358	NUT M18 X 2.5 NL	2	-
14	5545342	WASHER M18 FLA	2	-
15	5505116	MX-10_XPR-9/10 LIFT HEAD PIN WELDMENT	4	A
16	5595116	XP/XPR-9FDX Ø2.4 x 7.544 SAFETY CABLE	4	A
17	5570813	XP/XPR-9FDX HYDRAULIC HOSE ASSY Ø6.35 x 1.549mm DS	2	A
18	5575103	XP/XPR-9FDX CABLE ASSY Ø10 x 10.764mm SL	2	A
19	5570811	XP/XPR-9FDX HYDRAULIC HOSE ASSY Ø10 x 306.1mm DS	2	A
20	5746167	DOUBLE THREADED ROD M10 X 1.5 X 270	2	A

DO NOT SCALE DRAWING
DIMENSIONS ARE IN MM

DRAWN TM 02/10/2010
CHECKED AC 04/30/2010

THIRD ANGLE PROJECTION

NAME DATE
1645 LEMONWOOD DR.
BendPak, SANTA PAULA, CA 93060

TITLE: XPR-9FDX PARTS BOX

SIZE DWG. NO. A 5250123 REV B

SCALE: 1:25 SHEET 1 OF 1

PROPRIETARY AND CONFIDENTIAL
THIS DRAWING IS THE SOLE PROPERTY OF BENDPAK INC. ANY REPRODUCTION IN PART OR AS A WHOLE WITHOUT THE WRITTEN PERMISSION OF BENDPAK INC. IS PROHIBITED.

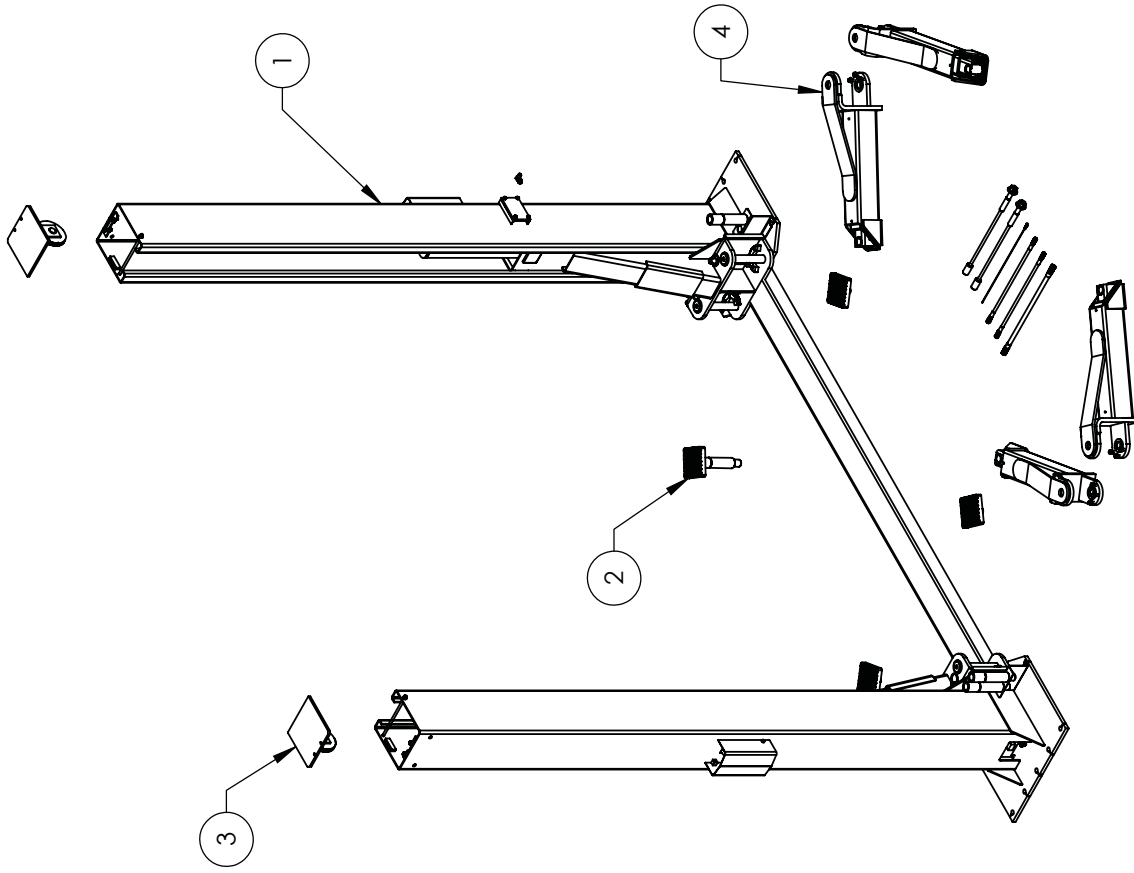

ITEM NO	PART NUMBER	DESCRIPTION	QTY	REV
1	5245137	XPR-12FD LIFT SUPERSTRUCTURE	1	B
2	5250132	XPR-12FD/XPR-12FD-LWB PARTS BOX	1	B
3	5215376	XP/XPR-12FD TOP EQUALIZER PULLEY PLATE ASSEMBLY	2	A
4	5210149	XPR-12C/FD TRIPLE TELESCOPING ARM ASSEMBLY	4	A

DO NOT SCALE DRAWING
 DIMENSIONS ARE IN MM

DRAWN TM 02/12/2010
 CHECKED AC 04/30/2010

NAME DATE



THIRD ANGLE PROJECTION

TITLE: XPR-12FD RECEIVED LIFT

SIZE (DWG. NO.): A 5260142

REV B

SCALE: 1:35

SHEET 1 OF 2

PROPRIETARY AND CONFIDENTIAL
 THE INFORMATION CONTAINED IN THIS DRAWING IS THE PROPERTY OF BENDPAK, INC. REPRODUCTION IN PART OR AS A WHOLE WITHOUT THE WRITTEN PERMISSION OF BENDPAK, INC. IS PROHIBITED.

**NOTE: UNLESS OTHERWISE SPECIFIED,
 1. SEE SHIPPING INSTRUCTIONS FOR FINAL PACKAGING**

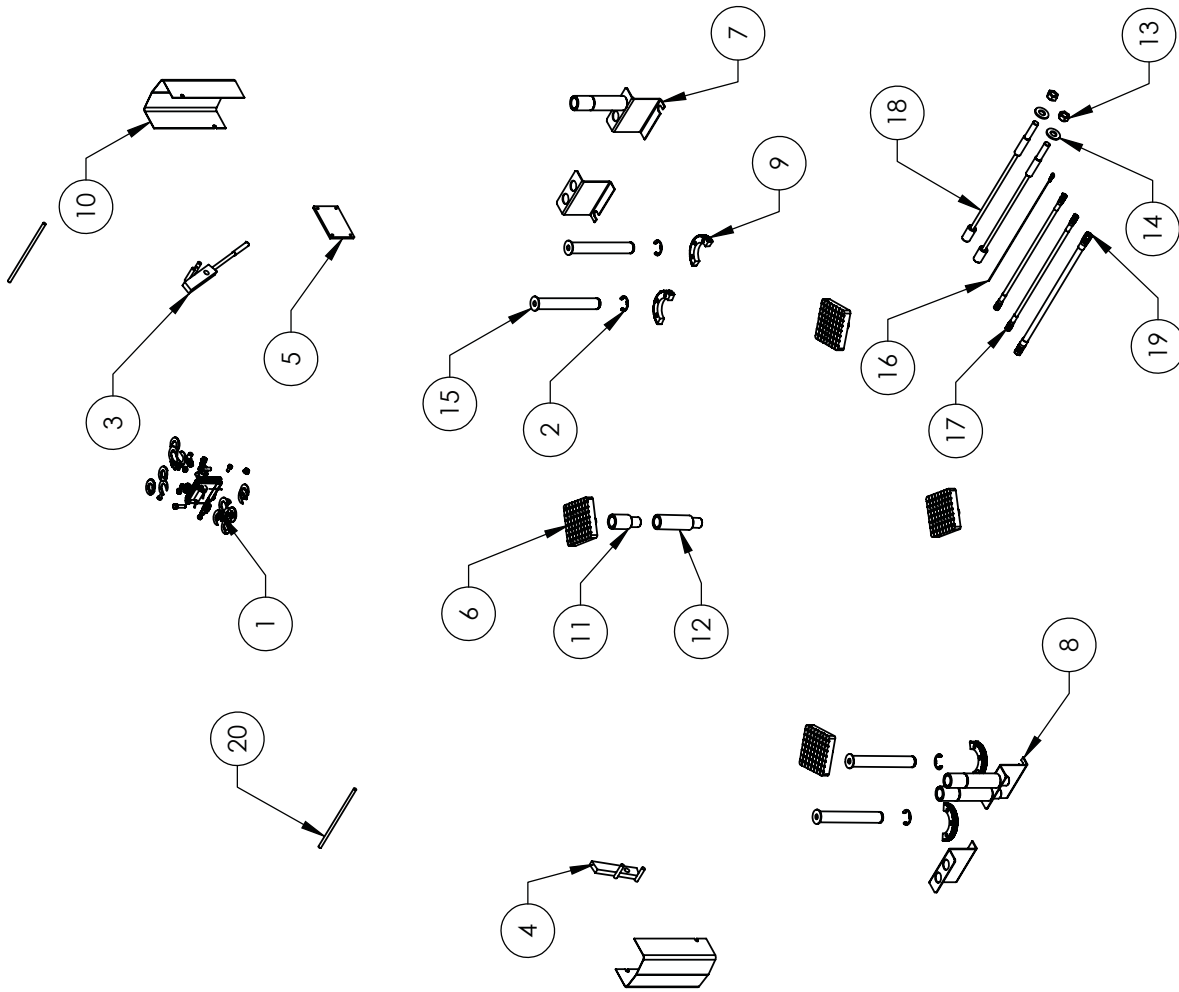

NOTE: UNLESS OTHERWISE SPECIFIED.

1. INSERT PARTS BAG INTO PARTS BOX FOR SHIPMENT
2. SEE SHIPPING INSTRUCTIONS FOR FINAL PACKAGING
3. THREAD 5535358 ONTO CABLES WITH 5545342 FOR SHIPMENT

NEXT ASSEMBLY	---
5260142	---
5260144	---



MATERIAL: ---
 SIZE: ---



THIRD ANGLE PROJECTION

TITLE: XPR-12FD/XPR-12FD-LWB
 PARTS BOX

REV	
A	5250132
B	
SCALE: 1:25	
SHEET 1 OF 1	

BendPak 1645 LEMONWOOD DR.
 SANTA PAULA, CA 93060

DRAWN	TM	02/12/2010
CHECKED	AC	04/30/2010

DO NOT SCALE DRAWING
 DIMENSIONS ARE IN MM

ITEM NO.	PART NUMBER	DESCRIPTION	QTY	REV
1	5174114	XPR-9FD/12FD/15FD PARTS BAG	1	B
2	5540129	FRINGE Ø38mm OD	4	A
3	5210007	XP/XP OFF SIDE SAFETY ASSEMBLY	1	A
4	5210010	XP/XP OFF SIDE SAFETY WELDMENT	1	A
5	5715003	POWER UNIT VIBRATION DAMPENER	1	A
6	5215250	MD-6XP ALL XP/XP SLIP ON LIFT PAD ASSEMBLY	4	B
7	5730670	XP/XP-12/15/18C POST ASSEMBLY LIFT HEAD FOOT GUARD RH	2	A
8	5730669	XP/XP-12C/12FD/15/18C POST ASSEMBLY LIFT HEAD FOOT GUARD LH	2	B
9	5736172	XP/12C/12FD/15/18C BOLLON ARM RESTRAINT GEAR	4	B
10	5210009	ALL XP, XPR-7/9FD/10/12/12FD/15/18C OFF SIDE SAFETY COVER	2	A
11	5746390	XP/XP/RJ/MX/MD-6XP SHORT LIFT PAD EXTENSION (113mm LG.)	4	A
12	5746395	MX/XP/XP LONG LIFT PAD EXTENSION (182mm LG.)	4	A
13	5538011	NUT M22 X 25	2	A
14	5545345	WASHER M22 X 50mm FLAT	2	B
15	5505346	XP/XP-12/15/18C LIFT HEAD PIN WELDMENT	4	A
16	55951724	XP/XP-12/15/18C LIFT HEAD PIN WELDMENT	1	A
17	5570118	XP-12F, XP/XP-12FD HYDRAULIC HOSE ASSEMBLY Ø6.35 x 1.562mm DS	2	A
18	5595070	XP-12FD CABLE ASSY Ø12 x 10800mm	2	B
19	5570126	XP/XP-12FD HYDRAULIC HOSE ASSY Ø10 x 3150mm DS	1	B
20	5746166	DOUBLE THREADED ROD M10 X 1.5 X 290	2	A

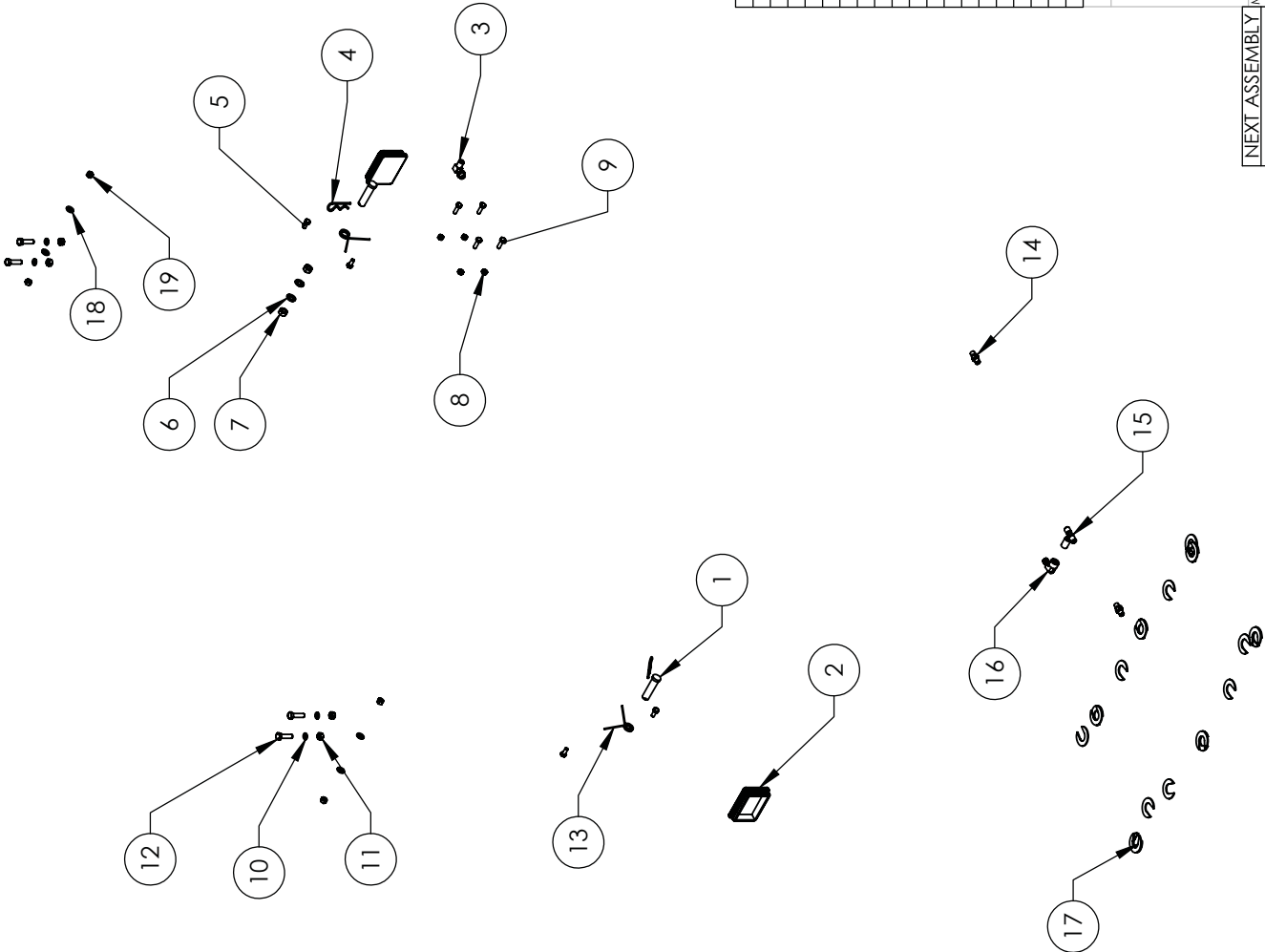

ITEM NO.	PART NUMBER	DESCRIPTION	QTY	REV
1	5505113	PL-6000/XPR SERIES SAFETY CLEVIS PIN	2	D
2	5715196	XPR PLASTIC COVER BLOCK 105 x 80	2	A
3	5550183	FIG ELB-06 JIC -041 ORB	1	-
4	5505350	MODEL#211 HAIR PIN/LARGE	2	-
5	5505014	HHB M8 x 1.25 x 18	4	-
6	5545347	WASHER M12 FLAT WASHER	2	-
7	5535354	HEX NUT M12 X 1.75	2	-
8	5530001	NUT M8 X 1.25 NL	4	-
9	5530010	HHB M8 x 1.25 x 25	4	-
10	5545251	WASHER M10 x 18mm SL	4	-
11	5535998	NUT M10 x 1.5	4	-
12	5530760	HEX HEAD BOLT M10 x 1.25 x 35	4	-
13	5540001	2.5 WIRE DIA. Ø25.5X150 LG.	2	-
14	5550147	FIG NPL-04 JIC X-04 NPT	2	-
15	5550178	FIG TEE-04 JIC -04 JIC -06 NPT	1	-
16	5550109	FIG ELB-06 JIC X-06 F NPT	20	-
17	5545335	C WASHER SHIM FOR LIFTS	4	-
18	5545341	WASHER M10 x Ø20 FLAT	4	-
19	5535013	NUT M10 x 1.5 NL	4	-

DO NOT SCALE DRAWING

DIMENSIONS ARE IN MM

NAME: TM DATE: 02/10/2010

DRAWN: AC CHECKED: AC DATE: 04/30/2010

THIRD ANGLE PROJECTION

PROPRIETARY AND CONFIDENTIAL
THE INFORMATION CONTAINED IN THIS DRAWING IS THE SOLE PROPERTY OF BENDPAK INC. ANY REPRODUCTION OR TRANSMISSION OF THIS DRAWING WITHOUT THE WRITTEN PERMISSION OF BENDPAK INC. IS PROHIBITED.

NEXT ASSEMBLY MATERIAL: ---
SIZE: ---

5250122
5250123
5250132

1645 LEMONWOOD DR.
SANTA PAULA, CA 93060

BendPak
Performance Innovations

TITLE: XPR-9FD/FDX/J12FD PARTS BAG

SCALE: 1:18

REV: B

5174114

SHEET 1 OF 1

**NOTE: UNLESS OTHERWISE SPECIFIED,
1. SEE SHIPPING INSTRUCTIONS FOR FINAL PACKAGING**

INSTALLATION FORM

Customer Name:		Date of Installation:
Company Name:		
Street Address:		
City:	State:	Zip:
Phone:	Fax:	

Pre-Install Agreement

I, (the undersigned) acting as the owner of the business listed above assume responsibility for any permits required, either state or county mandated, related to the installation and/or operation of this equipment. I assume responsibility for the concrete floor and condition thereof, now or later, where the above equipment model(s) are installed. I will assume all liability for losses, damages (including loss of use), expenses, demands, claims, and judgments in connection with or arising out of any personal injury or alleged damage to property, sustained or alleged to have been sustained in connection with, or to have arisen out of the condition and/or drilling of the concrete near or adjacent to the equipment model(s) listed above. If my employee(s) offer assistance of any kind during installation of the above equipment model(s) I hold the manufacturer and installation company harmless of all liability for losses, damages, expenses, claims, and judgments in connection with or arising out of any personal injury or alleged damage to property, sustained or alleged to have been sustained in connection with the installation of the above equipment model(s).

I understand that the lifts above are supplied with concrete fasteners meeting the criteria of the American National Standard "Automotive Lifts - Safety Requirements for Construction, Testing, and Validation" ANSI/ALI ALCTV-1998, and that I will be responsible for all charges related to any special regional structural and/or seismic anchoring requirements specified by any other agencies and/or codes such as the Uniform Building Code (UBC) and/or International Building Code (IBC).

Customer Signature: _____ Print Name: _____ Date: _____

Post-Installation Check-Off

- | | |
|--|--|
| <input type="checkbox"/> Base and Columns Properly Shimmed And Stable
<input type="checkbox"/> Anchor Bolts Tightened
<input type="checkbox"/> Runways Properly Attached and Secured
<input type="checkbox"/> Electric Power Supply Confirmed
<input type="checkbox"/> Cables / Chains Adjusted Properly
<input type="checkbox"/> Safety Locks Functioning Properly
<input type="checkbox"/> Check For Hydraulic Leaks
<input type="checkbox"/> Oil Level | <input type="checkbox"/> Lubrication of Critical Components
<input type="checkbox"/> Lift Adapters
<input type="checkbox"/> Check For Overhead Obstructions
<input type="checkbox"/> Runways Level
<input type="checkbox"/> All Screws, Bolts, and Pins Secured
<input type="checkbox"/> Surrounding Area and Lift Clean In Appearance
<input type="checkbox"/> Proper Operation, Maintenance and Safety Explained
<input type="checkbox"/> Operation and Safety Manual(s) Left at Site |
|--|--|

I, (the undersigned) confirm that the above installation procedure(s) were completed. I understand that I will be responsible for maintaining this equipment as outlined in the accompanied **Installation and Operation Manual** and **ANSI/ALI ALOIM Safety Requirements for Operation, Inspection and Maintenance**. I understand that personal injury and/or damage to property can occur if the above equipment model(s) are not maintained or used improperly and take full responsibility for training my employees on proper use and maintenance of this equipment. I hold the manufacturer and installation company harmless of all liability for losses, damages (including loss of use), expenses, demands, claims, and judgments in connection with or related to improper use, improper training, or lack of required maintenance. I understand that the warranty does not cover replacement of parts worn or damaged due to normal use or lack of required maintenance

Customer Signature: _____ Print Name: _____ Date: _____

Installer Signature: _____ Print Name: _____ Date: _____

Installer Company Name: _____

Street Address: _____

City: _____ State: _____ Zip: _____

Phone: _____ Phone (Other): _____



The best automotive service equipment on the planet.

**For Parts Or Service
Contact:**

**BendPak Inc. / Ranger Products
1645 Lemonwood Dr.
Santa Paula, CA. 93060**

**Tel: 1-805-933-9970
Toll Free: 1-800-253-2363
Fax: 1-805-933-9160**

**www.bendpak.com
www.rangerproducts.com**

pn# 5900042

