



PLEASE READ THE ENTIRE CONTENTS OF THIS MANUAL PRIOR TO INSTALLATION AND OPERATION. BY PROCEEDING YOU AGREE THAT YOU FULLY UNDERSTAND AND COMPREHEND THE FULL CONTENTS OF THIS MANUAL. FORWARD THIS MANUAL TO ALL OPERATORS. FAILURE TO OPERATE THIS EQUIPMENT AS DIRECTED MAY CAUSE INJURY OR DEATH.

REV B 09-16-10  
pn#5900239

## INSTALLATION AND OPERATION MANUAL

### 18 GALLON PORTABLE OIL DRAIN WITH PUMP AND DRAIN VALVE

Model:  
**RD-18G**  
VER B



Keep this operation manual near the machine at all times. Make sure that ALL USERS read this manual.

#### SHIPPING DAMAGE CLAIMS

When this equipment is shipped, title passes to the purchaser upon receipt from the carrier. Consequently, claims for the material damaged in shipment must be made by the purchaser against the transportation company at the time shipment is received.

#### BE SAFE

Ranger™ Oil Drains are designed and built with safety in mind. However, proper training and thoughtful operation on the part of the operator can increase your overall safety. DO NOT operate or repair this equipment without reading this manual and the important safety instructions shown inside.



1645 Lemonwood Dr.  
Santa Paula, CA. 93060, USA  
Tel: 1-805-933-9970  
Toll Free: 1-800-253-2363  
Fax: 1-805-933-9160  
www.rangerproducts.com

## WARRANTY POLICY

Ranger Products™ are backed by over 35 years of manufacturing experience. Every Oil Drain bearing the Ranger™ name is sold with the following warranty.

- ◆ Each Ranger Product™ is warranted to be free from defects in workmanship and material for a period of one year from the date of shipment provided that a written claim for such defect is made within that time.
- ◆ This warranty does not cover damage or defects caused by carelessness of the operator, misuse, abuse or abnormal use which in any way impairs the proper functioning of the equipment or by the use or addition of parts not manufactured by Ranger Products™ or its suppliers.

THIS WARRANTY IS EXPRESSLY MADE IN LIEU OF ANY AND ALL OTHER WARRANTIES EXPRESSED OR IMPLIED INCLUDING THE WARRANTIES OF MERCHANTABILITY AND FITNESS FOR A PARTICULAR PURPOSE.

If your Ranger Products™ machine is not functioning properly, call your Ranger Products™ dealer immediately. On some occasions, an independent contractor may be hired to do the repairs. Within the warranty period, a customer should not hire his own contractor unless it is authorized in writing by Ranger Products™.

If it is necessary to return equipment for repairs, your dealer will so advise you. When returning equipment for repairs, see that machines are properly crated and protected, and prepay transportation.

Defective parts replaced at no charge must be returned to your dealer or Ranger Products™ within 60 days of the date that the replacement parts are shipped; otherwise, you must pay for the replacement parts at the current selling price.

## SHIPPING DAMAGE

**If any damage is found, notify your carrier immediately and save all packaging materials for the carrier's inspector to examine. Failure to promptly report damage could result in denial of your claim.**

A trucking company's procedure for handling damage is as follows:

1. Immediately send out an inspector. An inspection report is filled out on the spot, a copy of which is given to the customer.
2. The **customer** has to call the carrier to request a claim form.
3. The customer mails in the claim form.
4. The claim usually takes two (2) months to process.

If a unit is seriously damaged, your Ranger Products dealer may be able to intervene, requesting that the damaged unit be returned and a new unit delivered.

## IMPORTANT SAFETY TIPS



**ALWAYS MAINTAIN A CLEAN WORK AREA.  
KEEP VISITORS AND ESPECIALLY  
CHILDREN AWAY FROM WORK AREA.**

**THIS OIL DRAIN IS TO BE OPERATED BY  
PROPERLY TRAINED PERSONNEL ONLY.  
OPERATION BY UNTRAINED  
PERSONNEL MAY RESULT IN INJURY  
AND /OR PROPERTY DAMAGE.**

## For Parts Or Service Contact:

**BendPak Inc. / Ranger Products  
1645 Lemonwood Dr.  
Santa Paula, CA. 93060  
Tel: 1-805-933-9970  
Toll Free: 1-800-253-2363  
Fax: 1-805-933-9160  
www.bendpak.com  
www.rangerproducts.com**



**THIS OPERATING MANUAL CONTAINS IMPORTANT DETAILS CONCERNING THE SAFE OPERATION OF THIS EQUIPMENT. THE USER MUST READ AND UNDERSTAND THESE DETAILS BEFORE ANY USE OF THE EQUIPMENT. THIS MANUAL MUST BE RETAINED FOR FUTURE REFERENCE.**

**OWNER/OPERATOR RESPONSIBILITY:**

The owner and/or operator shall study the product instructions and retain them for future reference.

The owner and/or operator shall have an understanding of the product operating instructions and warnings before operating the equipment.

Warning information shall be emphasized and understood. If the operator is not fluent in English, the product instructions and warnings shall be read to and discussed with the operator in the operator's native language by the purchaser/ owner or his designee, making sure that the operator comprehends its contents.



**INSPECTION**

Visual inspection should be made before each use of the Oil Drain. This inspection should check for abnormal conditions such as cracked welds, leaks, and damaged, loose or missing parts.

Any product that appears to be damaged in any way, is found to be worn or operated abnormally, must be removed from service immediately.

Any product that operates abnormally shall be removed from service until repaired by a qualified repair service center.

If the product is accidentally subjected to an abnormal load or shock, it must be taken out of service immediately and be inspected by a qualified repair or service center.

It is recommended that an annual inspection is performed on the Oil Drain and that any damaged or worn parts, decals or warning labels be replaced with manufacturer's specified parts.



**ALTERATIONS**

Because of potential hazards associated with this type of equipment, no alterations shall be made to the product.

FOR YOUR SAFETY AND TO PREVENT INJURY:



**WARNING!**

**DO NOT EXCEED RATED CAPACITY.**

**OVERLOADING CAN CAUSE DAMAGE TO OR FAILURE OF THE OIL DRAIN.**

**KEEP HANDS AND BODY CLEAR OF ALL PINCH POINTS.**

**THIS OIL DRAIN IS DESIGNED FOR USE ONLY ON HARD LEVEL SURFACES CAPABLE OF SUSTAINING THE LOAD. USE ON OTHER THAN HARD LEVEL SURFACES CAN RESULT IN INSTABILITY AND POSSIBLE LOSS OF LOAD.**

**NO ALTERATIONS TO THE OIL DRAIN SHALL BE MADE.**

**READ, STUDY AND UNDERSTAND THE OPERATING MANUAL PACKED WITH THIS EQUIPMENT BEFORE OPERATING.**

**FAILURE TO HEED THESE WARNINGS MAY RESULT IN LOSS OF LOAD, DAMAGE , AND/OR FAILURE RESULTING IN PROPERTY DAMAGE, PERSONAL OR FATAL INJURY.**

**DISPOSE OF USED OIL AND OTHER AUTOMOTIVE FLUIDS IN COMPLIANCE WITH LOCAL, STATE AND FEDERAL ENVIRONMENTAL LAWS AND REGULATIONS.**

# ASSEMBLY INSTRUCTIONS

1. Assemble the Oil Drain using the illustration below as a guide.

## PARTS BREAKDOWN

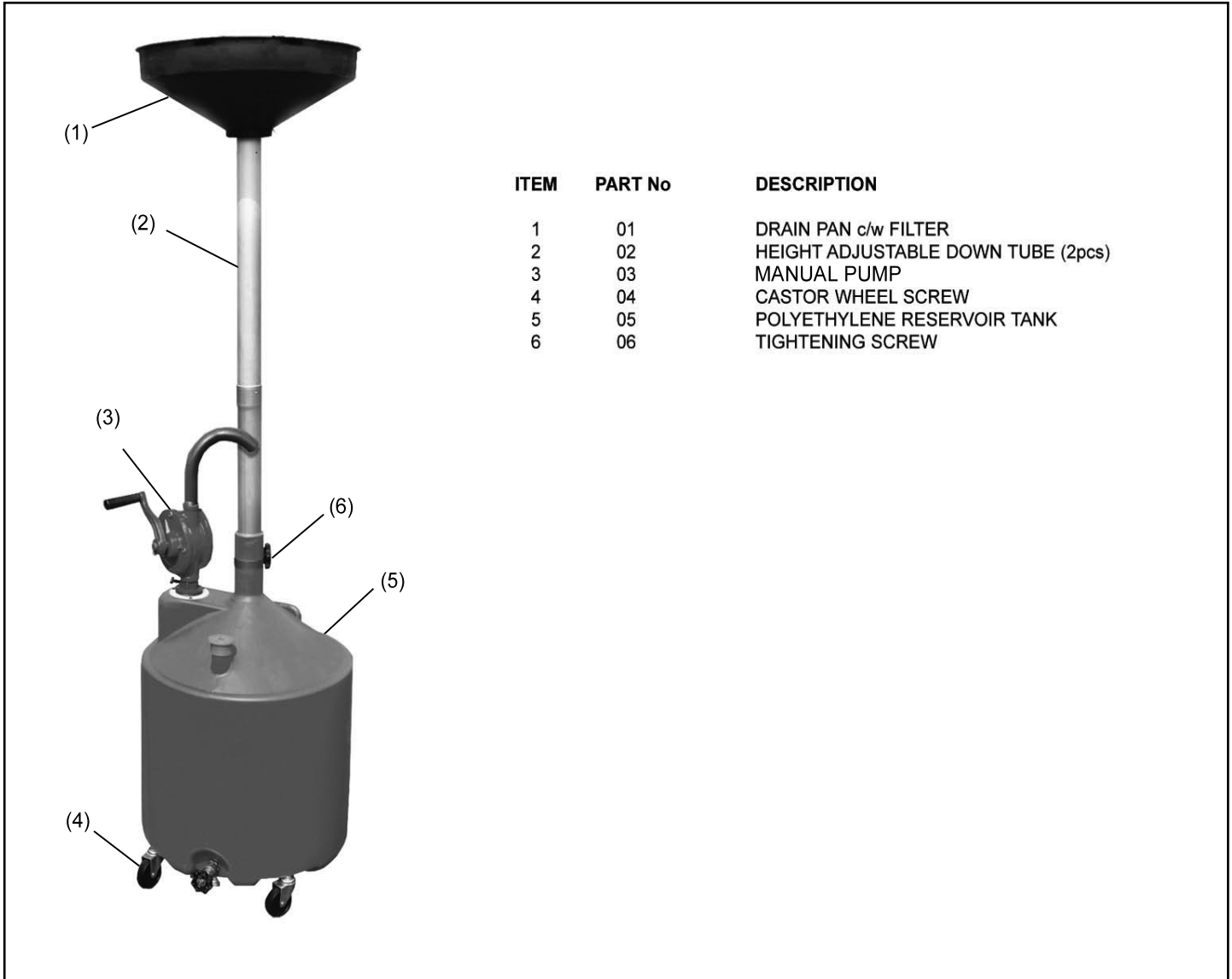

## SPECIFICATIONS

Funnel Diameter	Capacity	Adjustable	Shipping Weight	Shipping Dimensions
18" 457mm	18 Gallons 68 liters	37" - 71" 940mm -1,800mm	32 lbs 15 kg	19" x 19"x 30" 483mm x 483mm x 762mm



**Brand: Ranger**  
**Model: RP-20FC**  
**Description: Oil Filter / Can Crusher**

The Ranger RP-20FC oil filter crusher is an industrial crusher that conveniently reduces the size of used oil filters to one fourth of their original size. An integrated collection chamber and collector down-spout tube allows quick recovery of the oil for easy disposal to a drum or bulk container. Ideal for crushing automotive and light duty truck oil filters even the popular, 8" tall filters for Cummins and Powerstroke diesel-powered vehicles

**FEATURES**

- Save on disposal costs and storage space.
- Fulfills EPA and other mandated environmental standards.
- No mess design operates clean and efficiently - lessen spill hazards.
- Single control-valve operation.
- Exclusive X-shaped bevel in press head pre-aligns filters for absolute vertical press.
- Welded steel - plate construction.
- 12-1/2" diameter cylinder provides 20,000 lbs. crushing at 175 PSI.
- 20-second cycle time.
- Reduces filters to 25% of their original size.
- Removes up to 95% of the oil.
- 100% Air operated - very low maintenance.
- Automatic safety door stops operation when door is open.
- See-through door for convenient viewing of operation.
- Comes standard with pressure regulator and air moisture separator.
- Optional stand accommodates 5, 16 and 55-gallon drums for efficient fluid handling.

**SPECIFICATIONS**

- Overall Height: 29-1/2" / 749 mm.
- Overall Width: 17" / 432 mm.
- Overall Depth: 17" / 432 mm.
- Chamber Opening Height: 11" / 279 mm.
- Chamber Opening Width: 8" / 203 mm.
- Chamber Opening Depth: 11" / 279 mm.
- Average cycle time: 15-20 seconds
- Air input: 125-175 PSI
- Unit Weight: 228 lbs. / 103 kg.





**For Parts Or Service  
Contact:**

**BendPak Inc. / Ranger Products  
1645 Lemonwood Dr.  
Santa Paula, CA. 93060**

**Tel: 1-805-933-9970  
Toll Free: 1-800-253-2363  
Fax: 1-805-933-9160**

**[www.bendpak.com](http://www.bendpak.com)  
[www.rangerproducts.com](http://www.rangerproducts.com)**

pn#5900239

