



**Model(s): HDS-18E / HDS27 / HDS27X**

**Description: Heavy-Duty Four-Post Lifts**

BendPak's "HDS-Truck Series" four-post lifts are newly engineered heavy-duty truck lifts that make light work out of heavy lifting. They work better, are built to last, and feature upgrades that increase safety, durability and productivity. The HDS-18E, HDS-27, and extended length HDS-27X four-post models provide a generous 18,000 and 27,000-lb. lifting capacity and feature extra-wide runways to accommodate a wide variety of vehicles configurations.



**Features**

- Supersized 12" diameter cable sheaves within the runway and cross tubes combined with massive 3" diameter sheave axles dramatically improve cable wear and critical component lifespan meaning you'll increase safety and spend less money in service related expenses down the road.
- BendPak's HDS-Truck Series lifts feature four stainless-steel lifting cables that provide a great balance between abrasion resistance and fatigue.
- Grease nipples are located on every sheave and sheave axle to make lubrication maintenance a breeze.
- Each HDS-Truck Series four-post lift is equipped with a single hydraulic cylinder hidden away under the runway for maximum performance and reliability and minimum exposure to elements. The hydraulic cylinder features high-durometer rod seals, pressure loaded U-cup piston seals, backups and wear bands that virtually eliminate any fluid bypass. The welded cylinder body is made from high strength steel tubing produced to exceed ASTM specifications. This combination of superb base material and superior processing ensures straight, smooth, cylinders that will provide years and years of dependable trouble-free service.
- An integrated hydraulic flow restrictor provides a controlled descent in the unlikely event of an unexpected hose rupture.
- A durable powder coat finish can withstand harsh environments and chemical spills and will provide years of protection.
- Spring-loaded safety locks automatically engage continuously during rise and adjustable safety ladders allow for precise runway leveling even when installed on sloped floors.
- A simple push-button pneumatic lock release makes lowering operations simple and fast. Aircraft-quality stainless steel and aluminum pneumatic cylinders will provide years of trouble-free service.
- A secondary lock system is on constant guard and acts as a slack-cable device in the unlikely event of an unexpected cable failure.
- Lifting cables, airlines, safety latches and sheaves are all fully enclosed within lift structure.
- Features multiple adjustable height locking positions for variable-height parking and infinite leveling.
- A maintenance-free electric hydraulic power system assures ultimate dependability.
- All operator controls are conveniently located within easy reach.
- 12" x 12" base plates provide a solid foundation.
- Non-skid runways provides maximum grip, even when the runway surface is wet or oily.



- Optional rolling jacks make a great addition to increase service capacity. Rolling jacks are used to raise the front or rear portion of a vehicle off the runways allowing operators to perform efficient wheel and break service. A pair of jacks allows the entire vehicle to be elevated. Each jack has telescoping arms and frame contact pads that can be extended over the runways and positioned under vehicle lifting points. Each jack features three safety-lock positions and stackable truck and van adapters for increased lifting height and better access to frame contact points on high ground-clearance vehicles. The jacks come equipped with a commercial grade air-hydraulic pump.

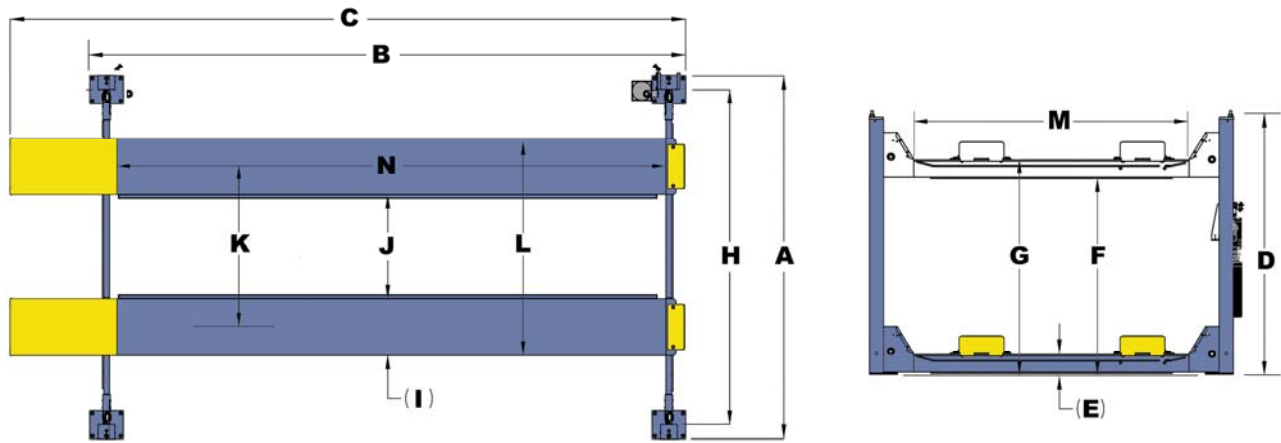

### Specifications

MODEL	HDS-18E	HDS-27	HDS-27X
Lifting Capacity*	18,000 lbs. / 8165 Kg.	27,000 lbs. / 12,247 Kg.	27,000 lbs. / 12,247 Kg.
*Max Capacity / Front Axle	9,000 lbs. / 4082 Kg.	13,500 lbs. / 6,124 Kg.	13,500 lbs. / 6,124 Kg.
*Max Capacity / Rear Axle	9,000 lbs. / 4082 Kg.	13,500 lbs. / 6,124 Kg.	13,500 lbs. / 6,124 Kg.
A - Overall Width	154" / 3912 mm.	154" / 3912 mm.	154" / 3912 mm.
B - Outside Length	257" / 6528 mm.	257" / 6528 mm.	317" / 8052 mm.
C - Overall Length	297" / 7544 mm.	297" / 7544 mm.	357" / 9068 mm.
D - Height of Columns	93" / 2362 mm.	93" / 2362 mm.	93" / 2362 mm.
E - Min. Runway Height	8-1/2" / 216 mm.	8-1/2" / 216 mm.	8-1/2" / 216 mm.
F - Max. Rise	60" / 1524 mm.	60" / 1524 mm.	60" / 1524 mm.
G - Max. Lifting Height	68-1/2" / 1740 mm.	68-1/2" / 1740 mm.	68-1/2" / 1740 mm.
H - Width Between Columns	134" / 3404 mm.	134" / 3404 mm.	134" / 3404 mm.
I - Runway Width	22" / 559 mm.	22" / 559 mm.	22" / 559 mm.
J - Width Between Runways (*) MIN	38" / 965 mm.	38" / 965 mm.	38" / 965 mm.
J - Width Between Runways (*) MAX	56" / 1422 mm.	56" / 1422 mm.	56" / 1422 mm.
K - Runway Centerline (*) MIN	60" / 1524 mm.	60" / 1524 mm.	60" / 1524 mm.
K - Runway Centerline (*) MAX	78" / 1981 mm.	78" / 1981 mm.	78" / 1981 mm.
L - Outside Edge of Runways (*) MIN	82" / 2083 mm.	82" / 2083 mm.	82" / 2083 mm.
L - Outside Edge of Runways (*) MAX	100" / 2540 mm.	100" / 2540 mm.	100" / 2540 mm.
M - Drive-Thru-Clearance	109" / 2769 mm.	109" / 2769 mm.	109" / 2769 mm.
N - Length of Runways	263" / 6680 mm.	263" / 6680 mm.	323" / 8204 mm.
Min. Wheelbase @ Rated Capacity	185" / 4699 mm.	185" / 4699 mm.	230" / 5842 mm.
Min. Wheelbase @ 75% Capacity	160" / 4064 mm.	160" / 4064 mm.	195" / 4953 mm.
Min. Wheelbase @ 50% Capacity	135" / 3429 mm.	135" / 3429 mm.	165" / 4191 mm.
Min. Wheelbase @ 25% Capacity	110" / 2794 mm.	110" / 2794 mm.	130" / 3302 mm.
Locking Positions	9	9	9
Lock Spacing	Every 6" / 152 mm.	Every 6" / 152 mm.	Every 6" / 152 mm.
Lifting Time	75 Seconds	75 Seconds	75 Seconds
Standard Motor (***)	220 VAC / 60 Hz. 1Ph.	220 VAC / 60 Hz. 1Ph.	220 VAC / 60 Hz. 1Ph.